

Izidor Hafner

Mazes for Superintelligent

Ginzburg projection

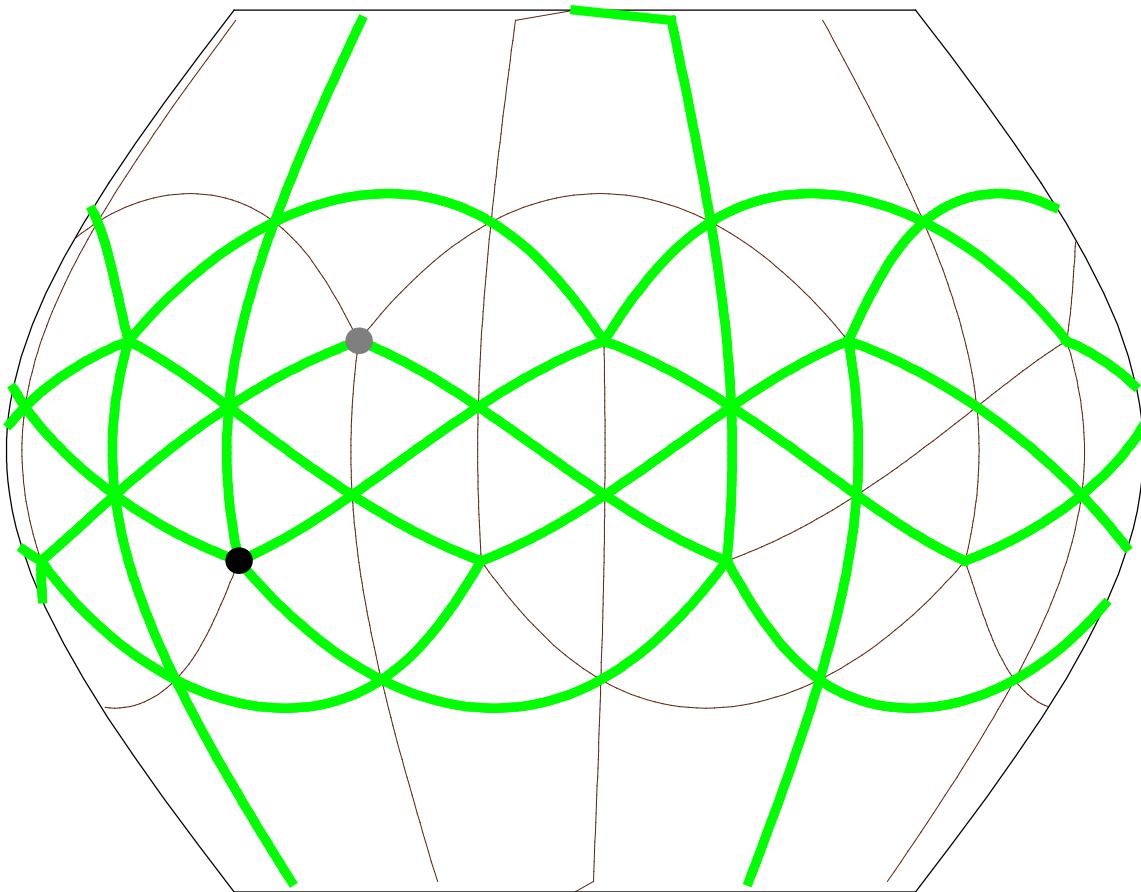
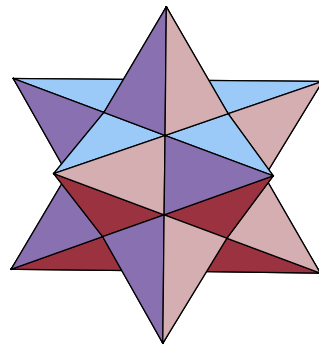
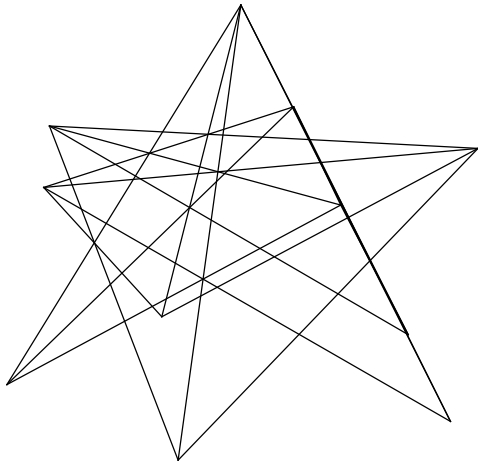

Introduction

Let us take an example. We are given a uniform polyhedron.

rhombicuboctahedron

{4, 3, 4, 4}

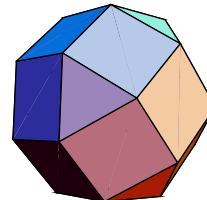
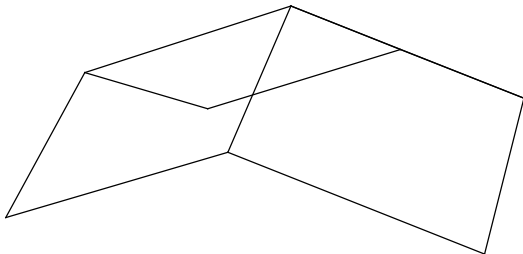

In Mathematica the polyhedron is given by a list of faces and with a list of coordinates of vertices [Roman E. Maeder, The Mathematica Programmer II, Academic Press 1996]. The list of faces consists of a list of lists, where a face is represented by a list of vertices, which is given by a matrix. Let us show the first five faces:

$$\begin{pmatrix} \{1, 2, 6, 3\} \\ \{1, 3, 4\} \\ \{1, 4, 10, 5\} \\ \{1, 5, 8, 2\} \\ \{2, 8, 14, 7\} \end{pmatrix}$$

The next two figures represent faces and vertices. The polyhedron is projected onto a sphere and the sphere is projected by a cartographic projection.

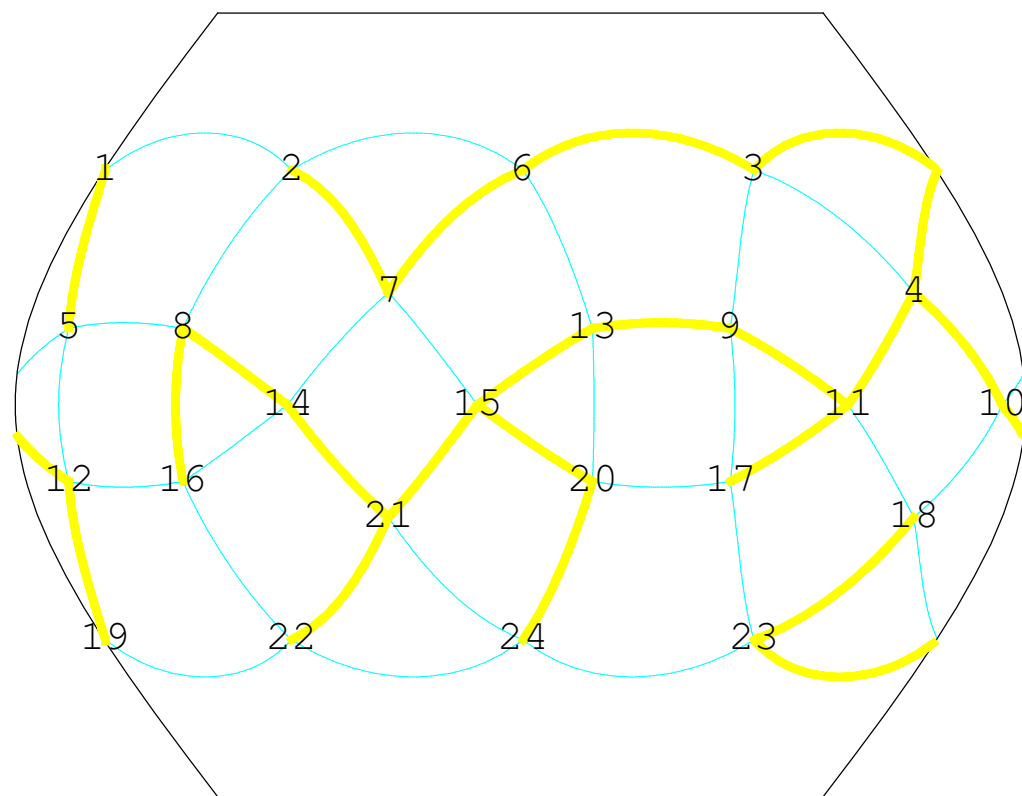
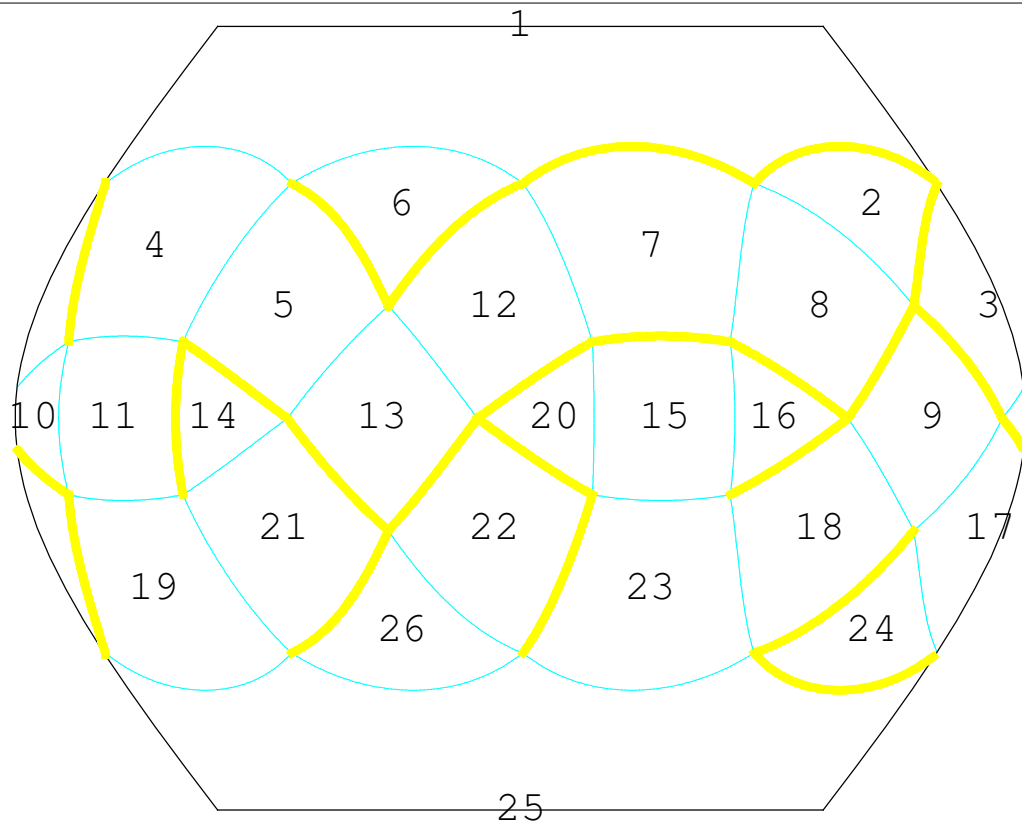

The problem is to find the path from the black dot to gray dot, where thick lines represent walls of a maze.

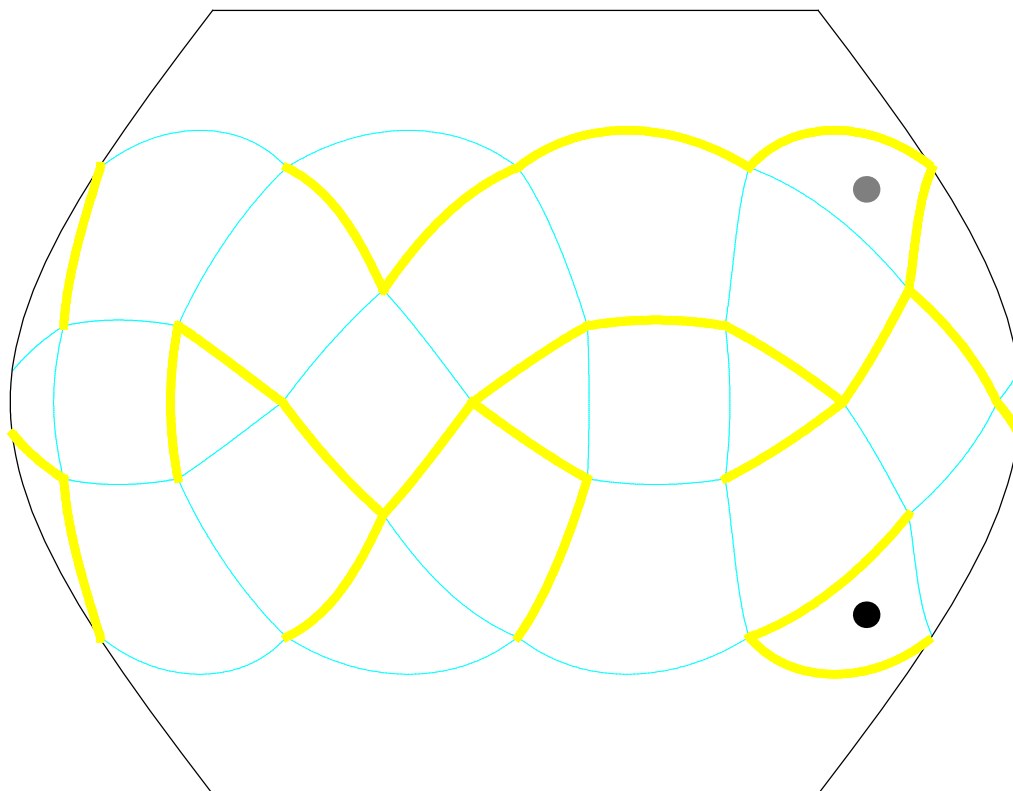

The solution is given by a list of faces passed from the black to gray dot.

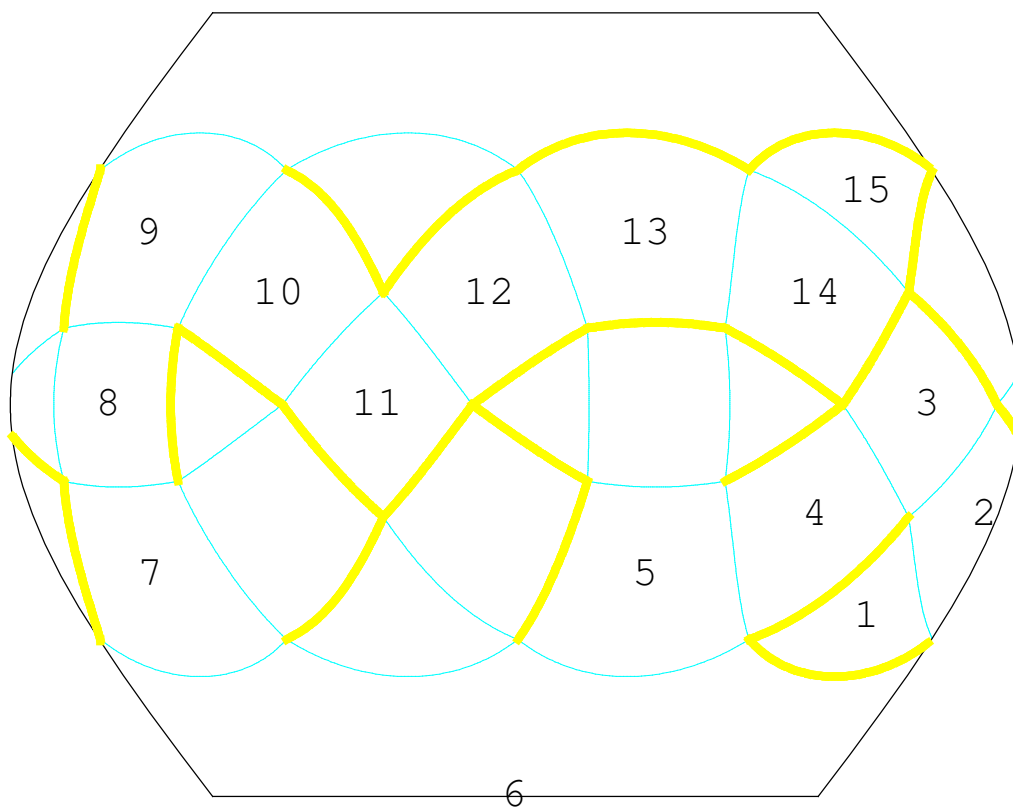

Problems

1.

tetrahedron

{3, 3, 3}

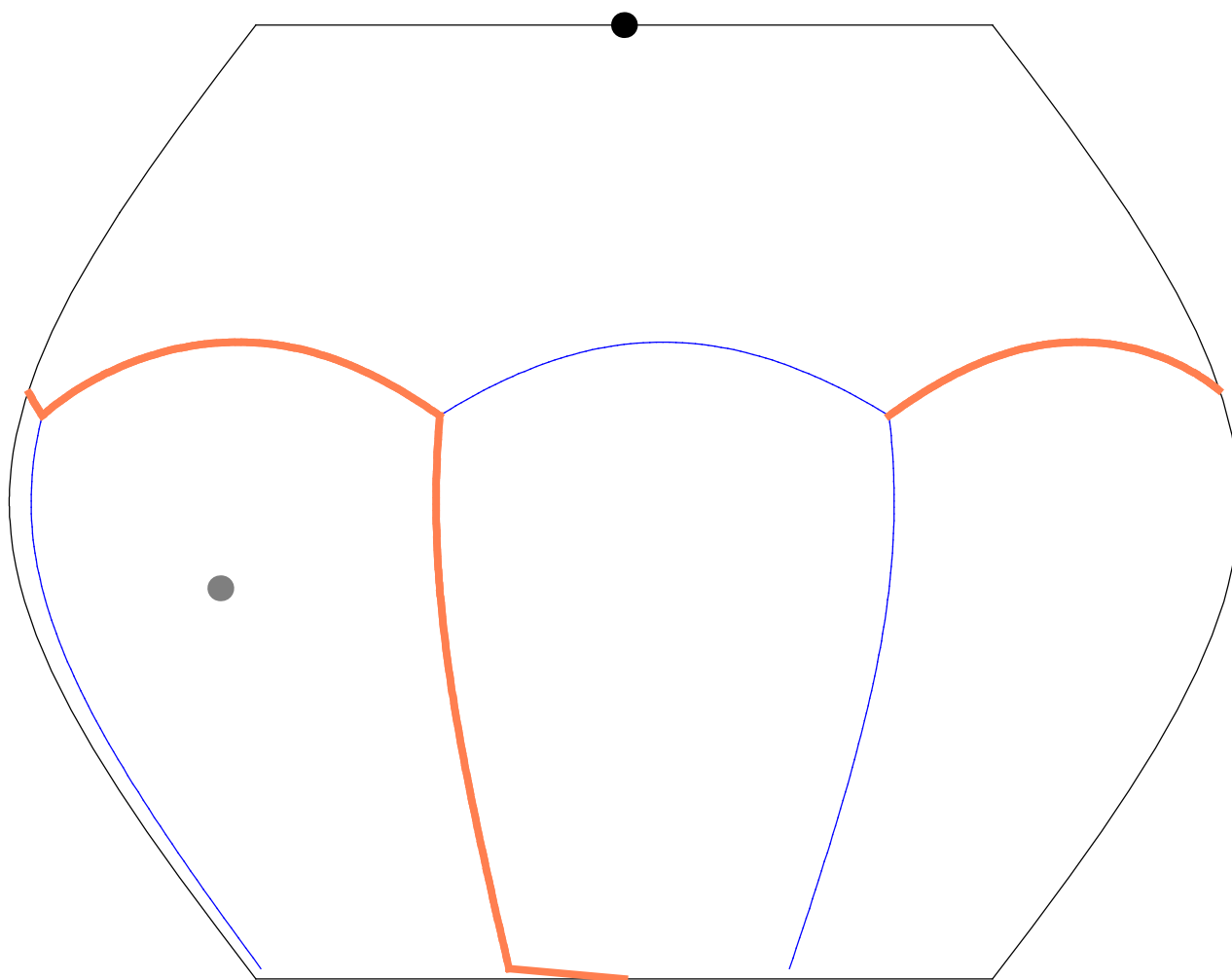
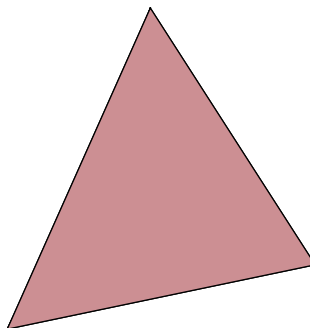
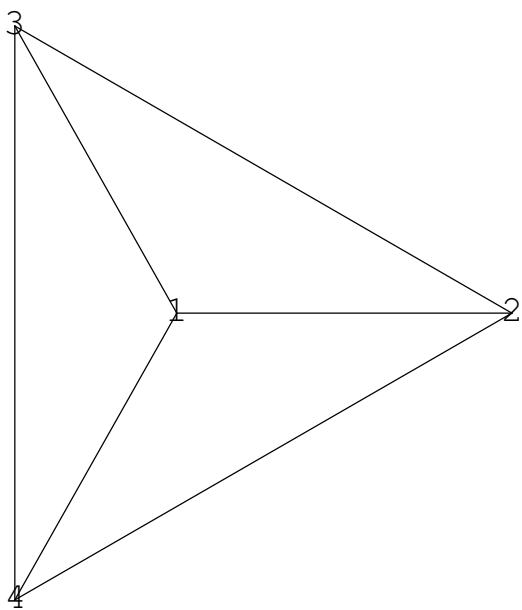

2.

truncated tetrahedron

{6, 6, 3}

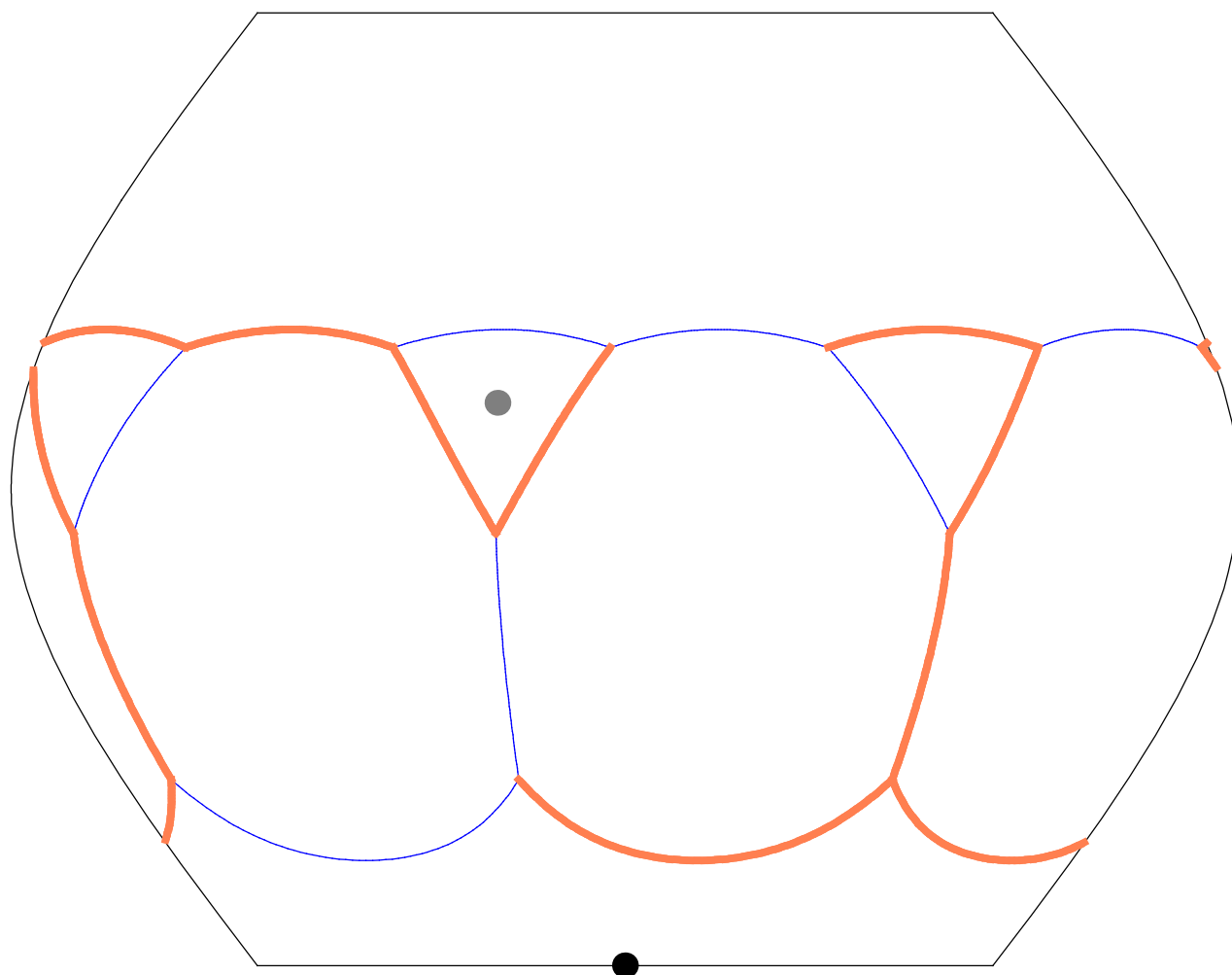
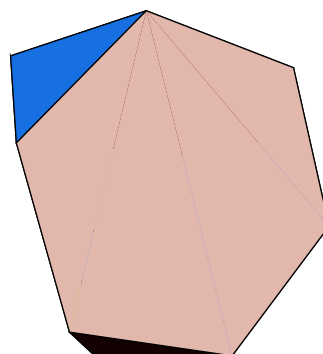
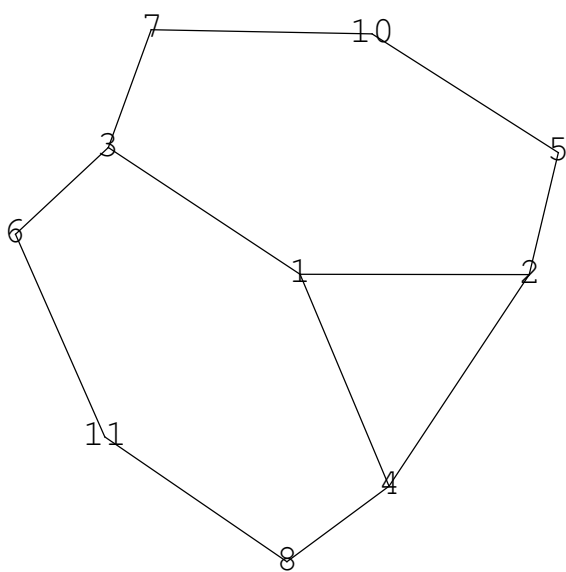

3.

octahemioctahedron

$$\{6, \frac{3}{2}, 6, 3\}$$

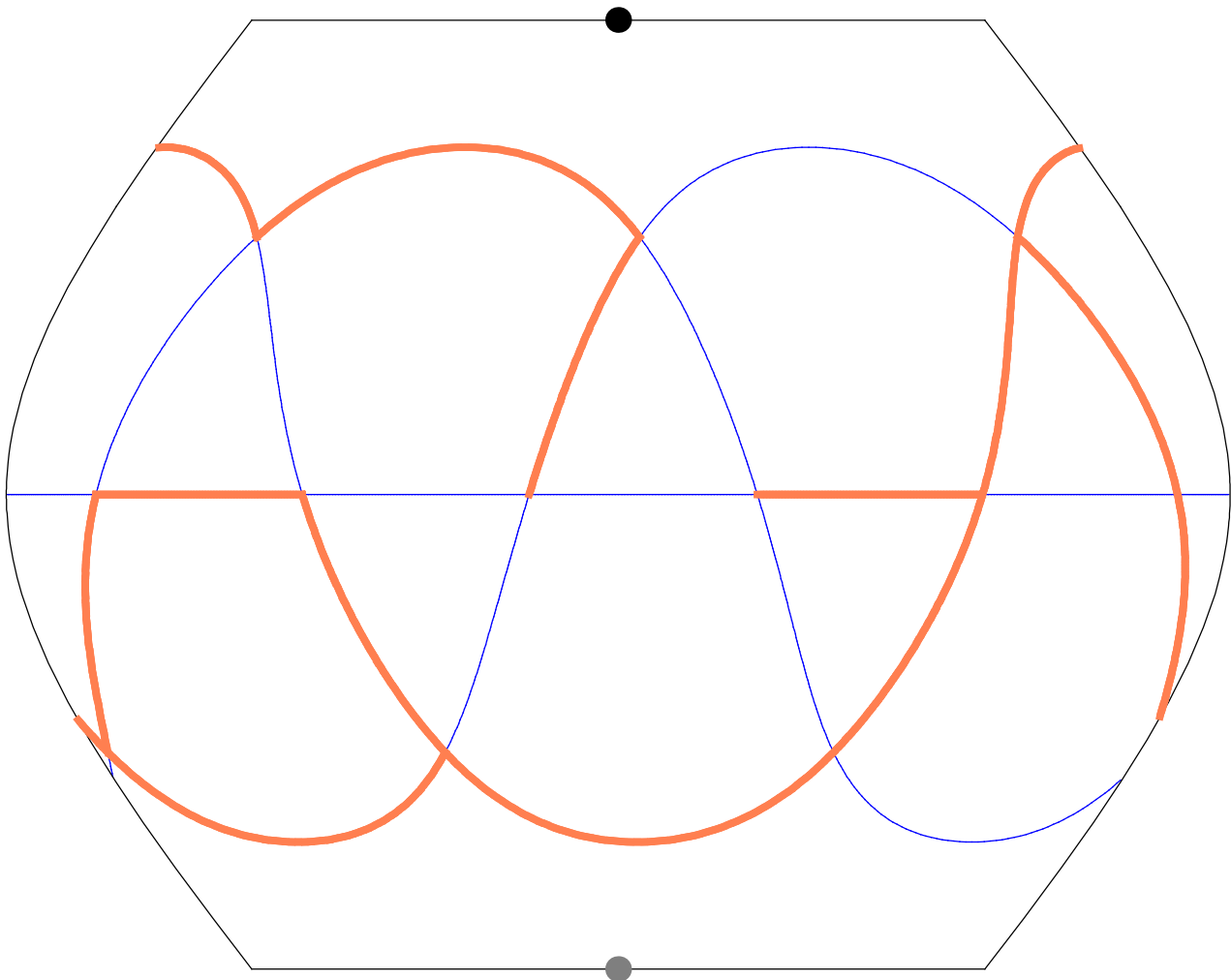
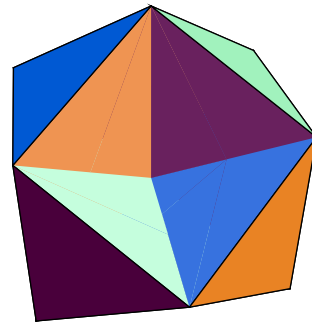
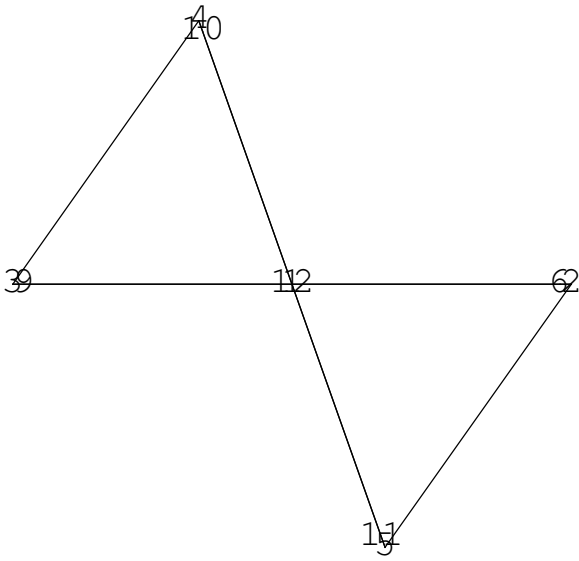

4.

tetrahemihexahedron

$$\left\{4, \frac{3}{2}, 4, 3\right\}$$

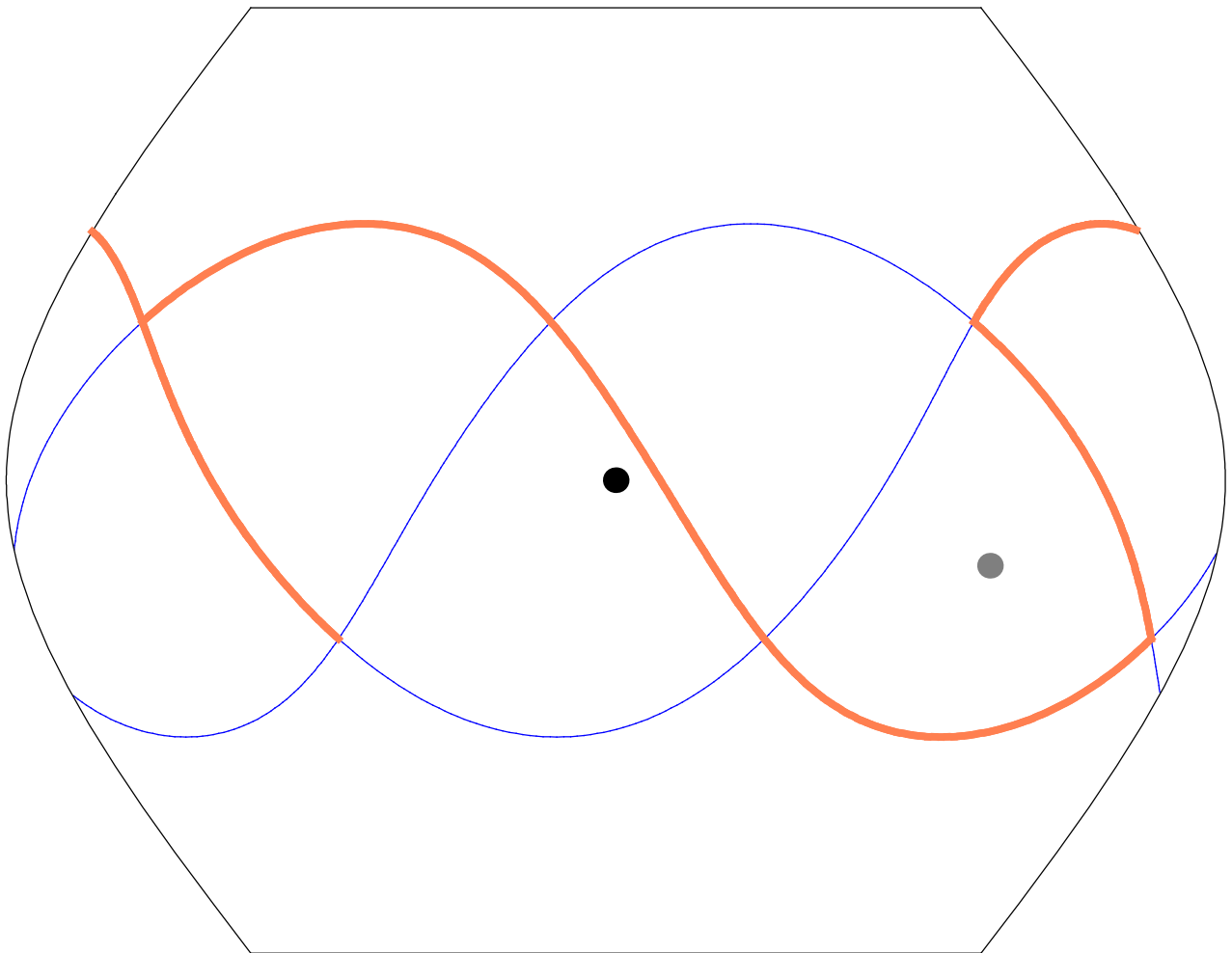
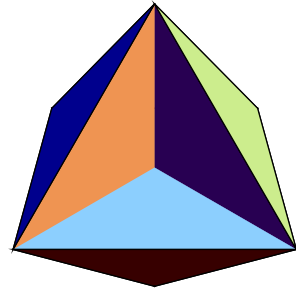
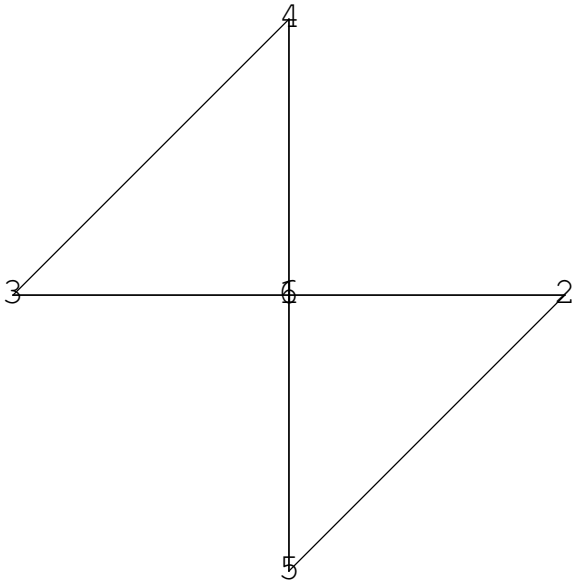

5.

octahedron

{3, 3, 3, 3}

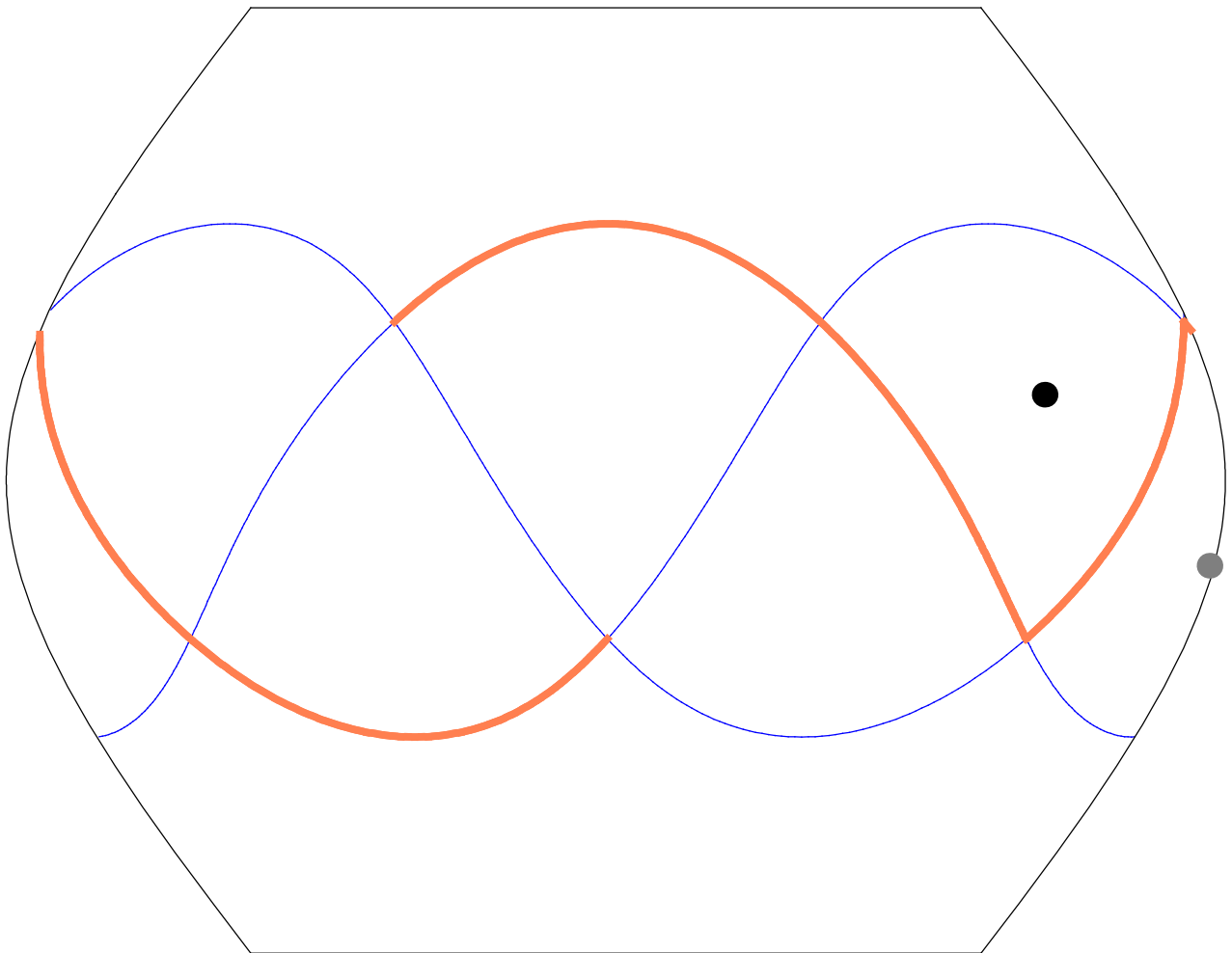
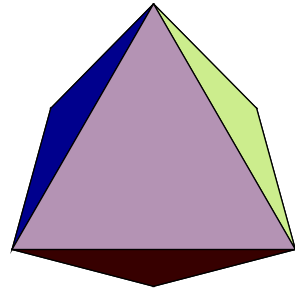
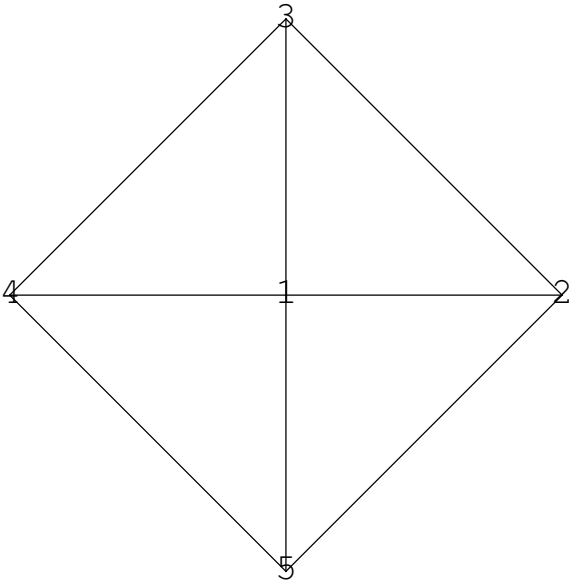

6.

cube

{4, 4, 4}

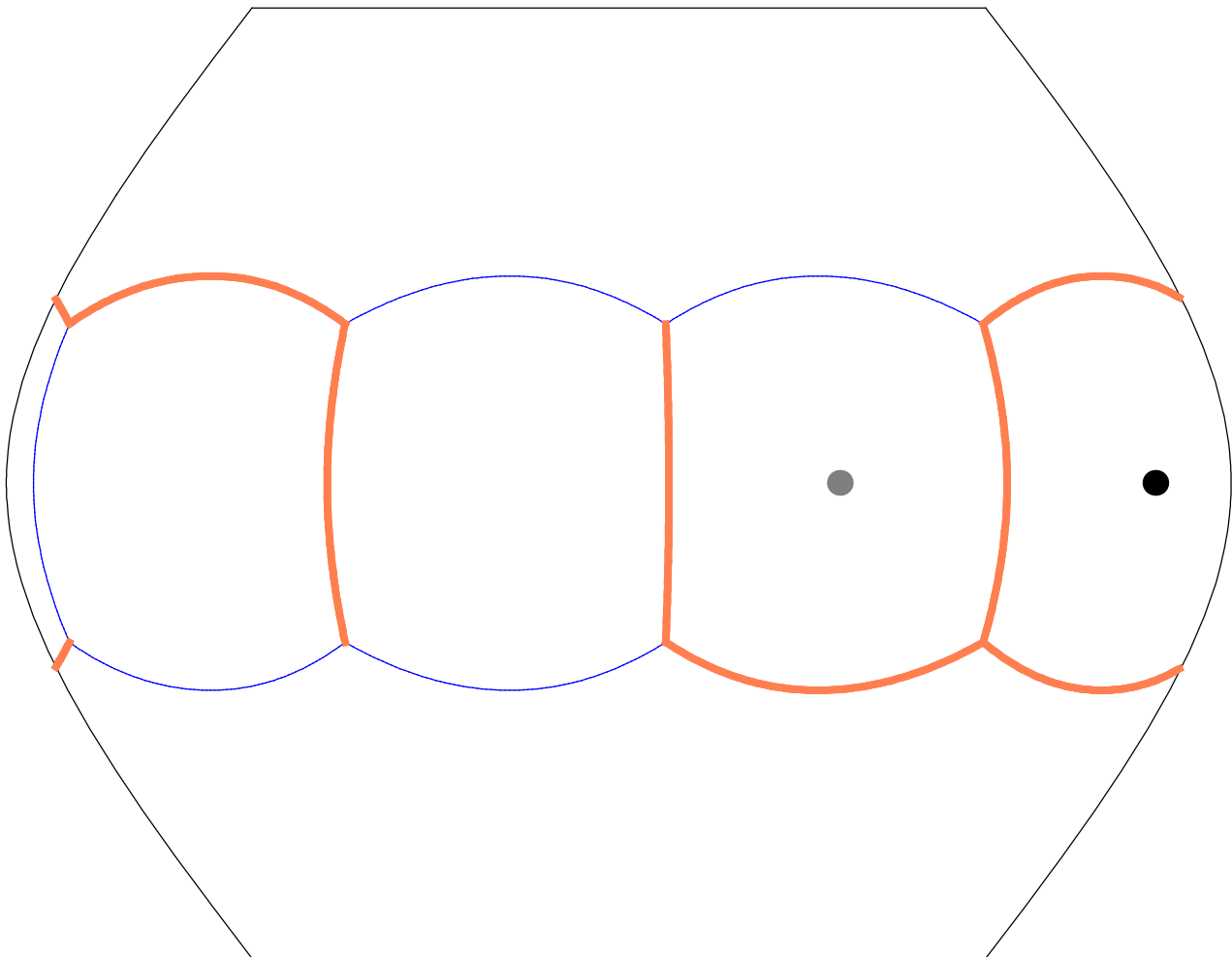
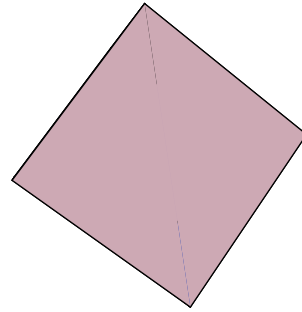
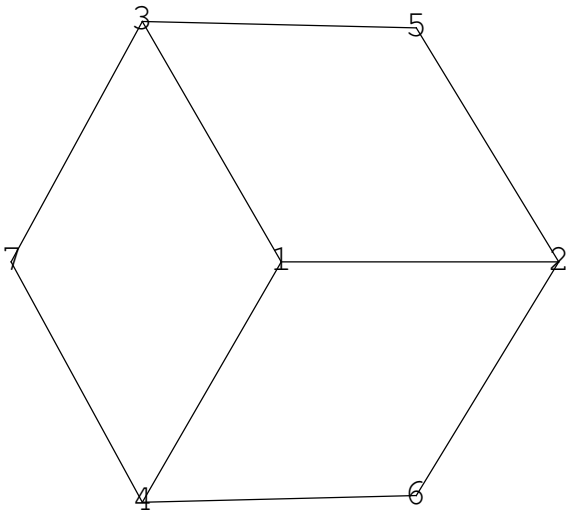

7.

cuboctahedron

{3, 4, 3, 4}

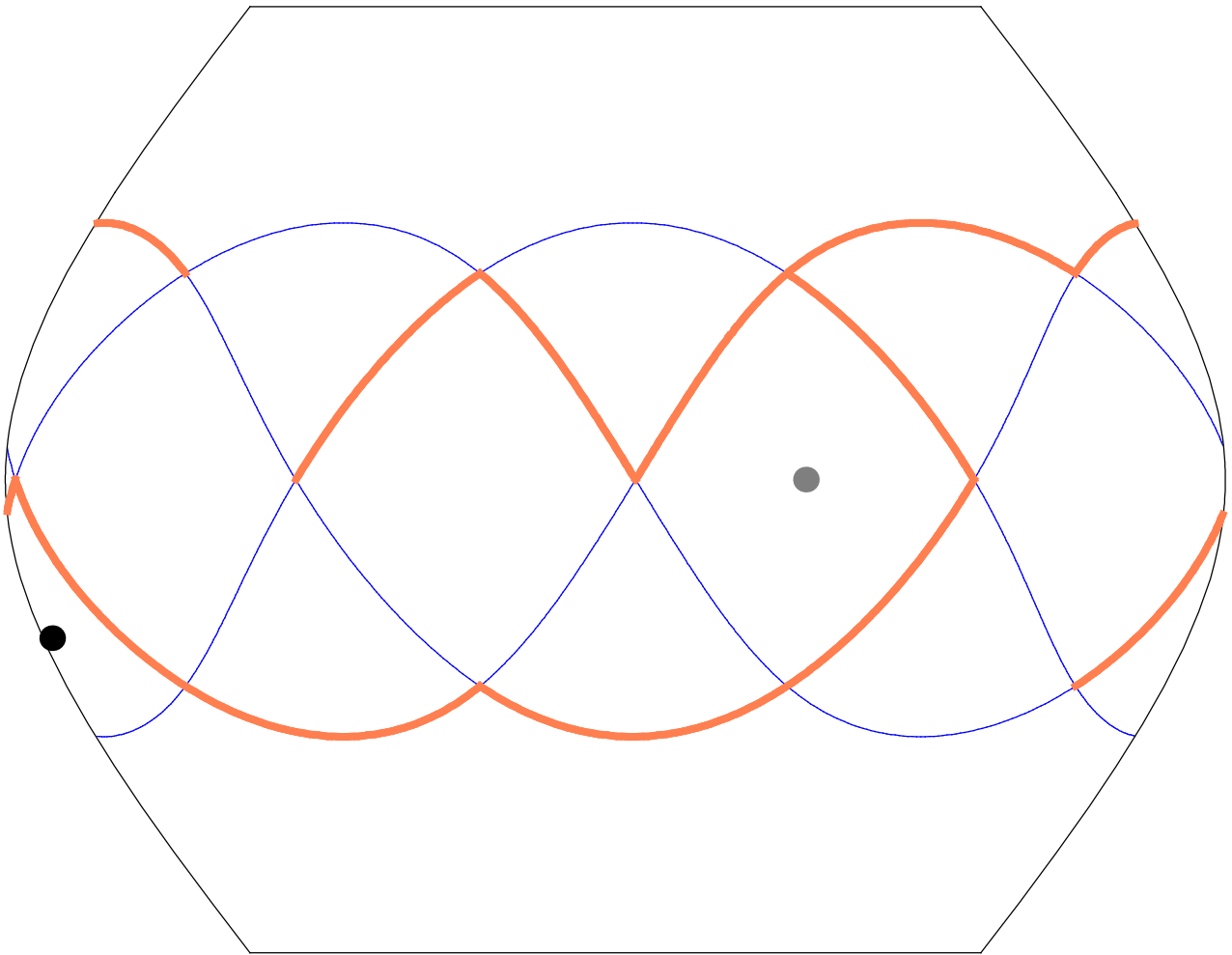
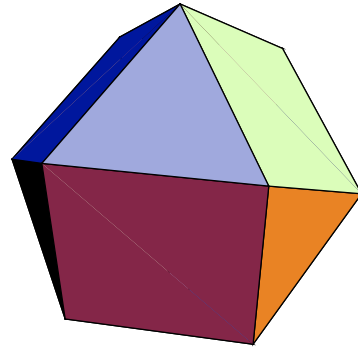
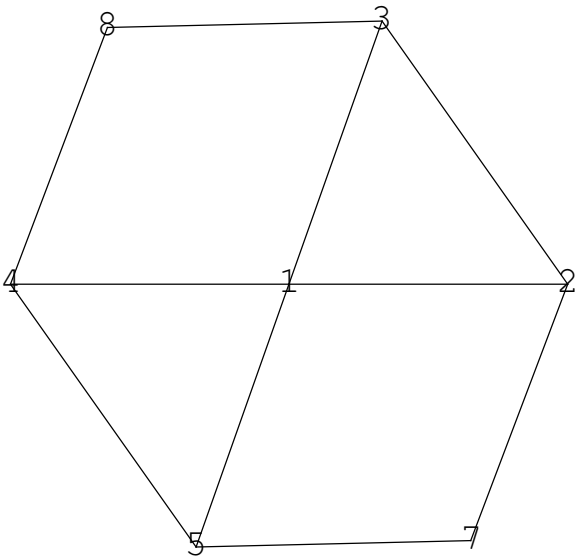

8.

truncated octahedron

{6, 6, 4}

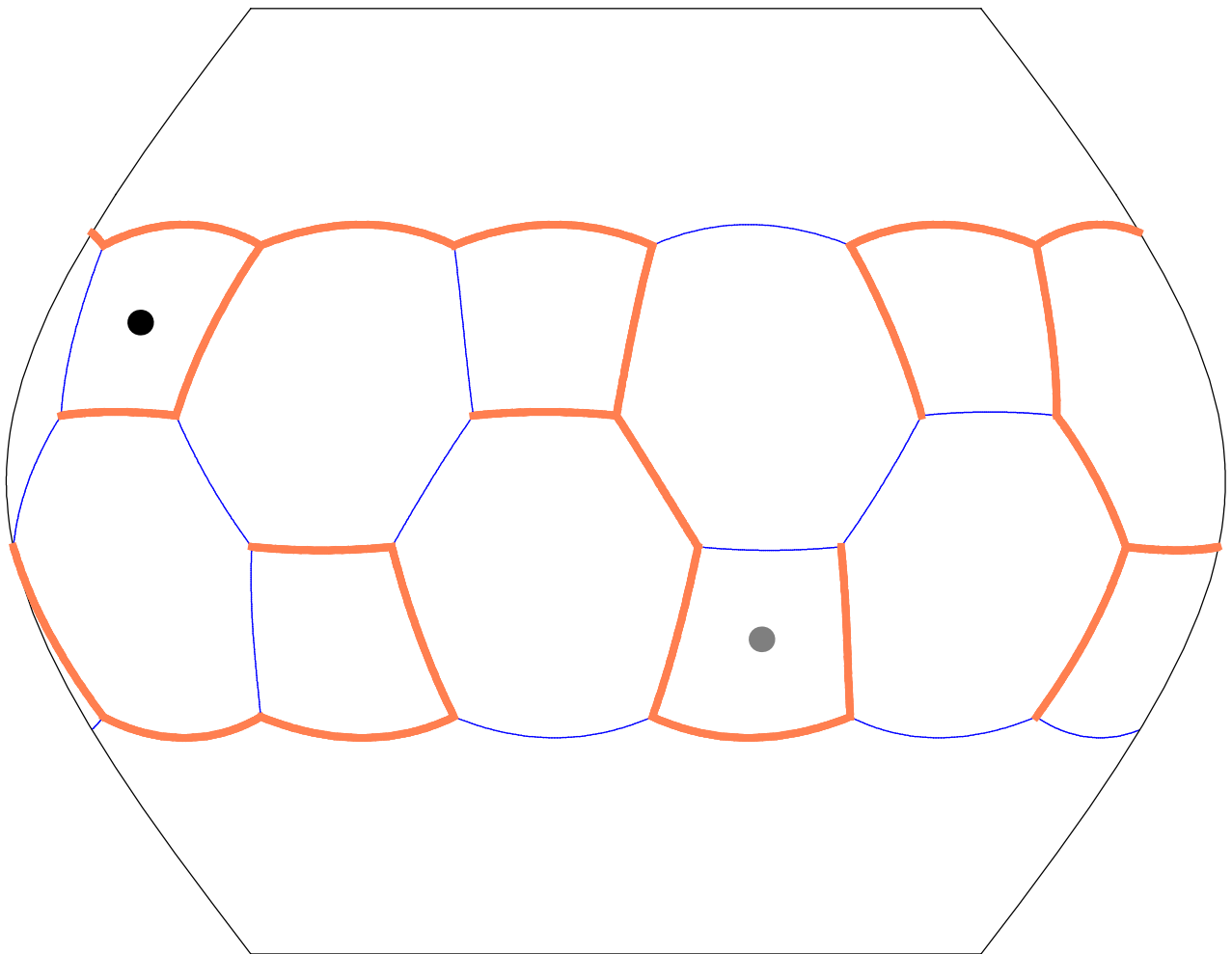
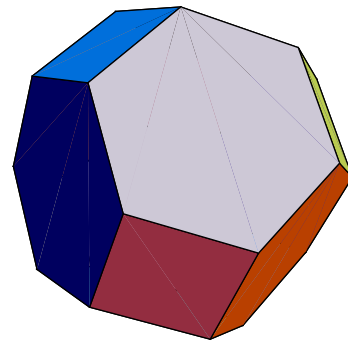
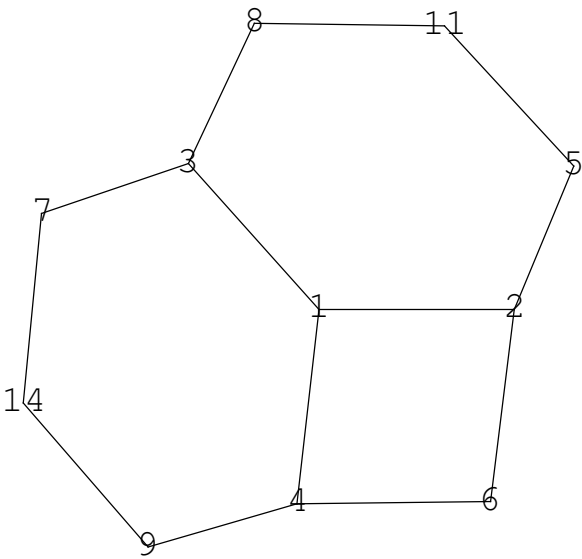

9.

truncated cube

{8, 8, 3}

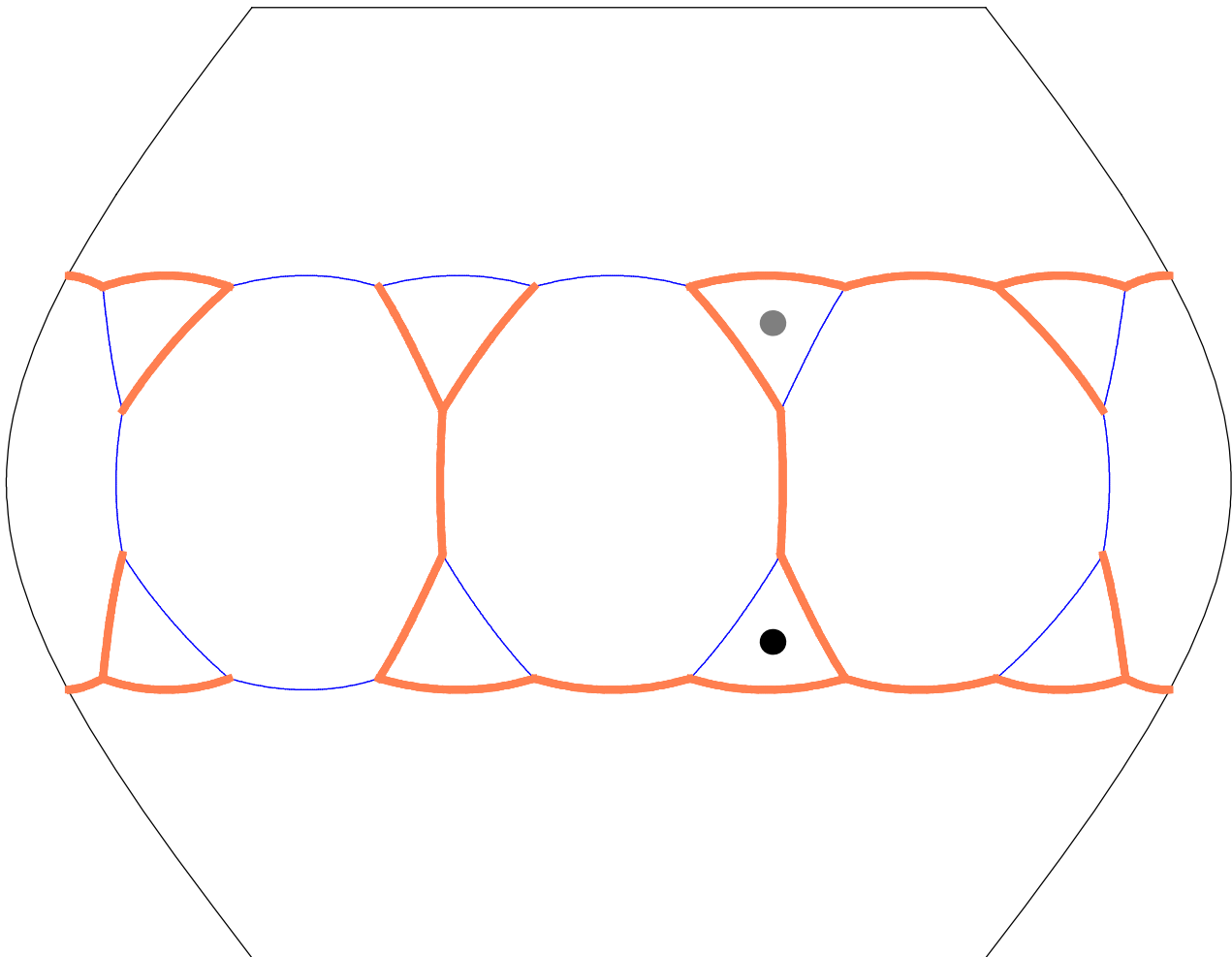
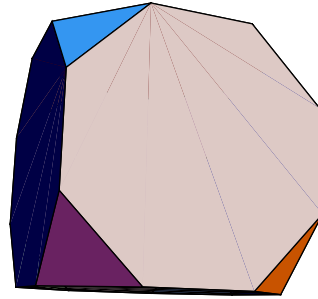
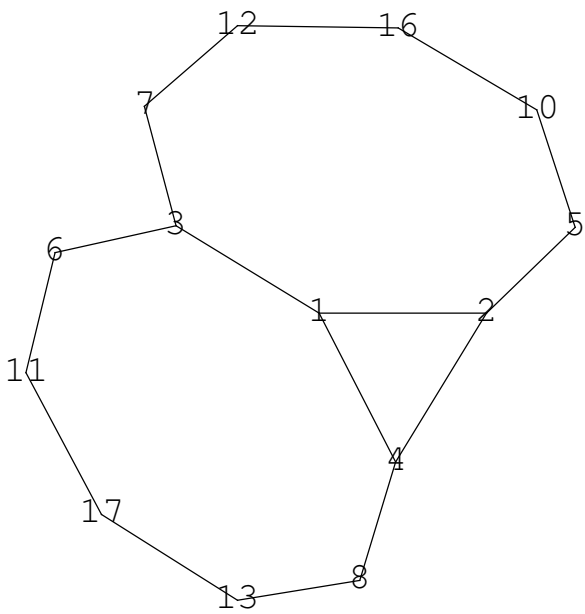

10.

rhombicuboctahedron

{4, 3, 4, 4}

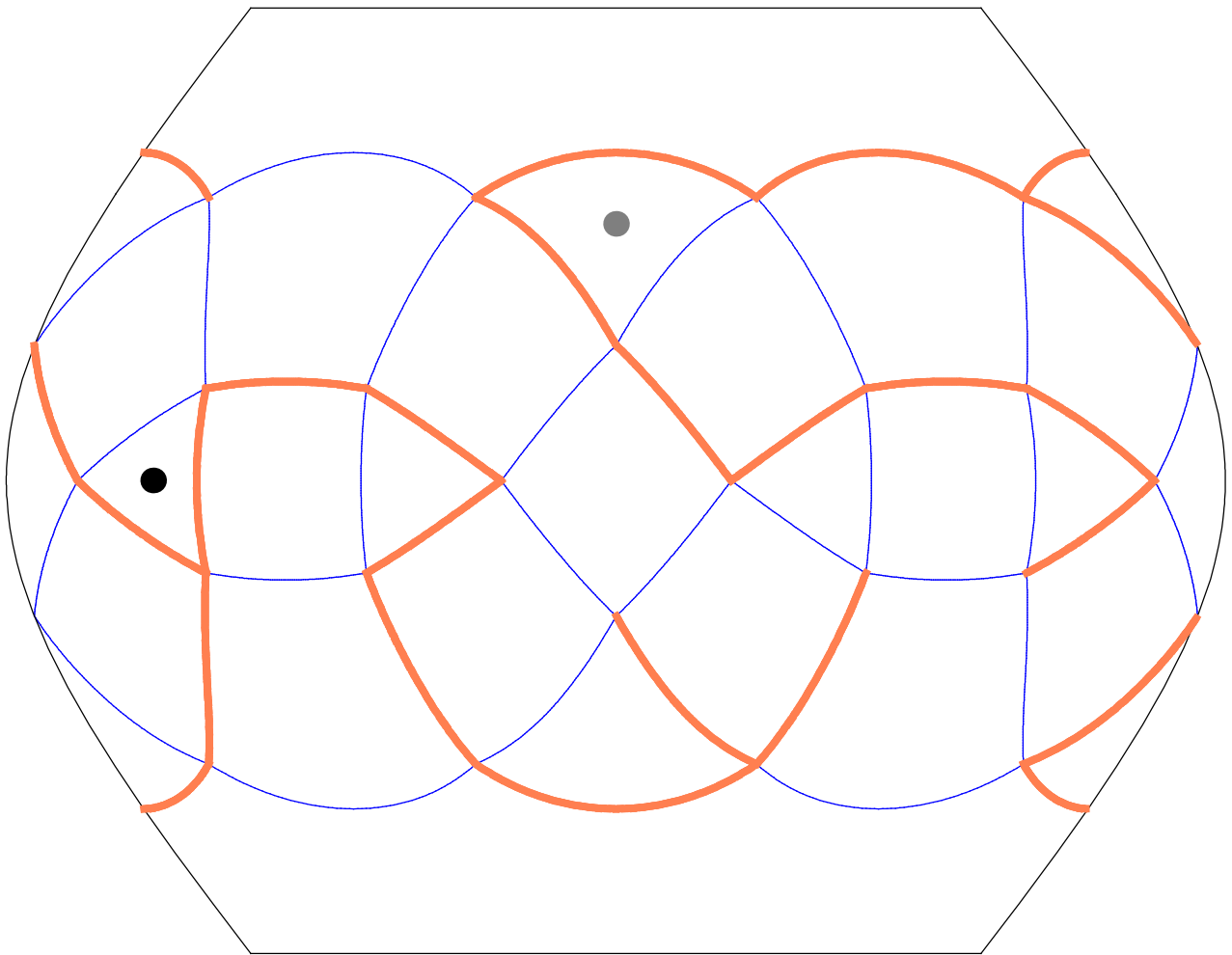
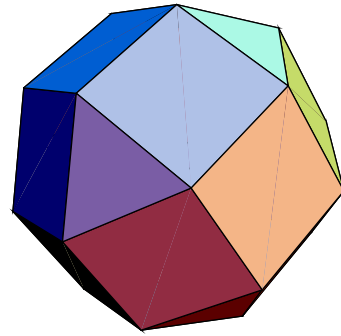
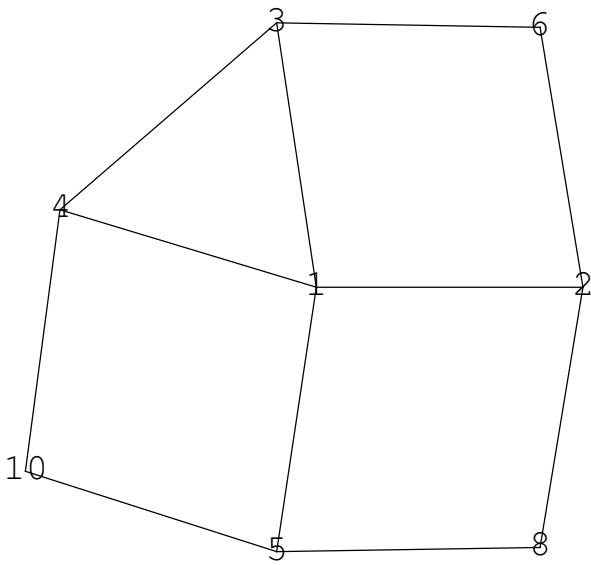

11.

truncated cuboctahedron

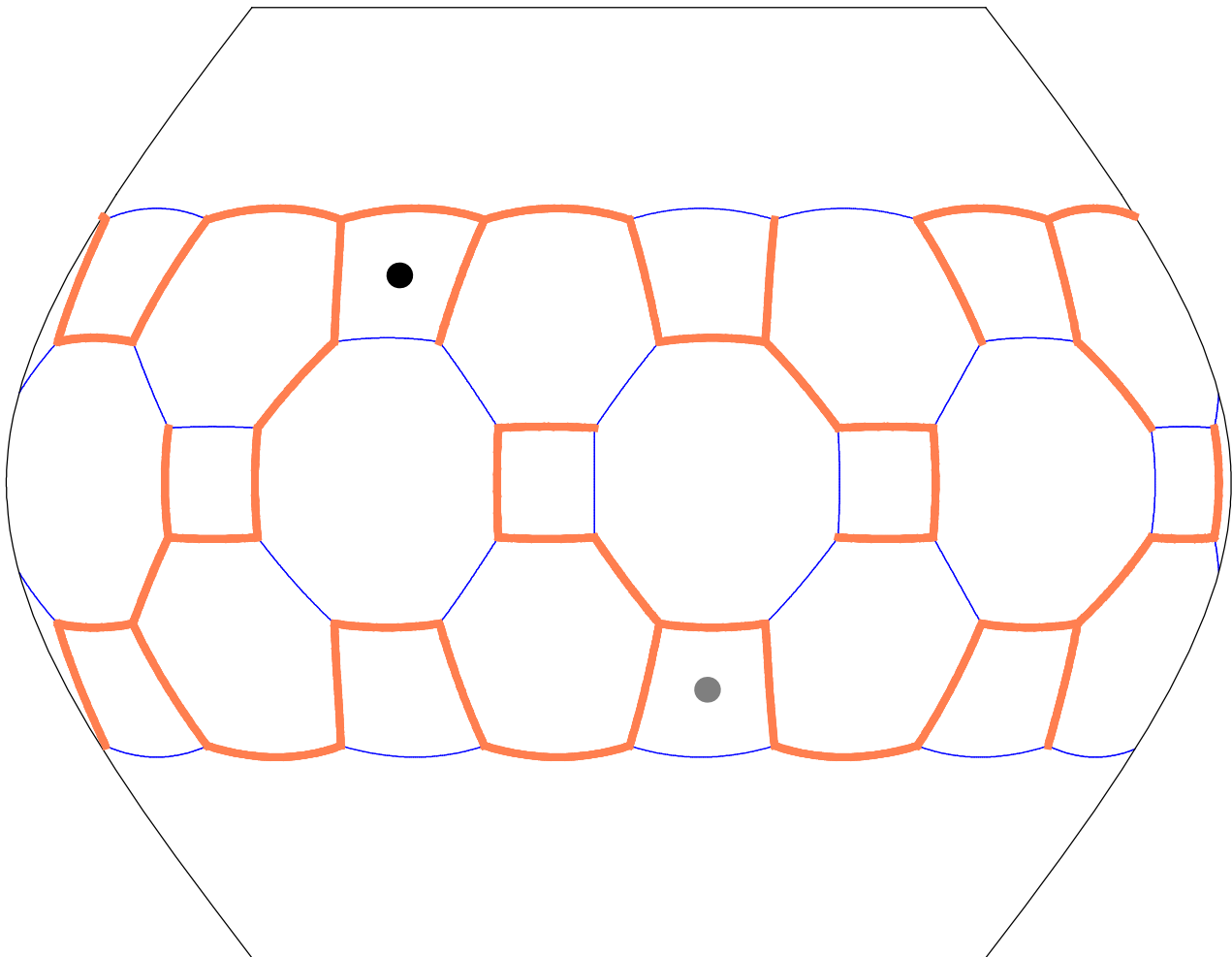
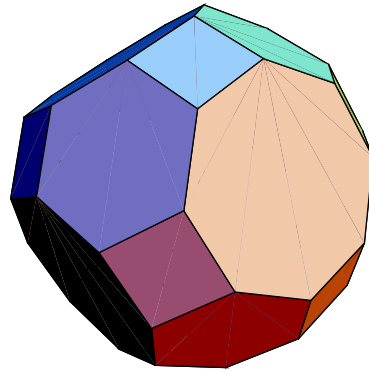
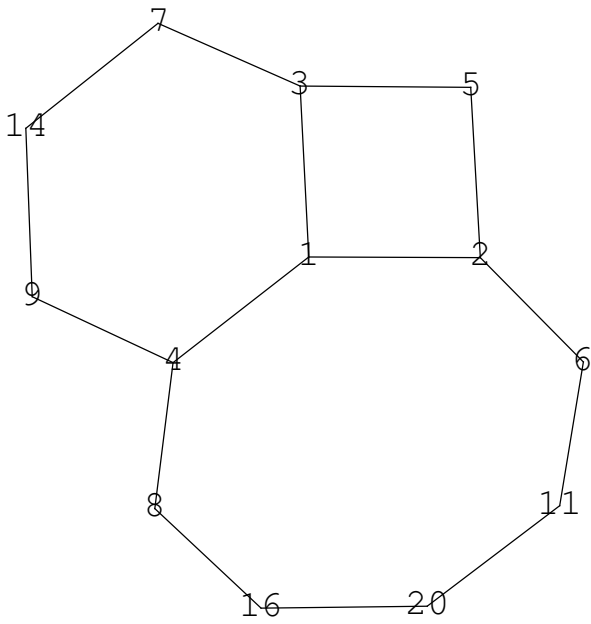
 $\{4, 6, 8\}$ 

12.

snub cube

{3, 3, 3, 3, 4}

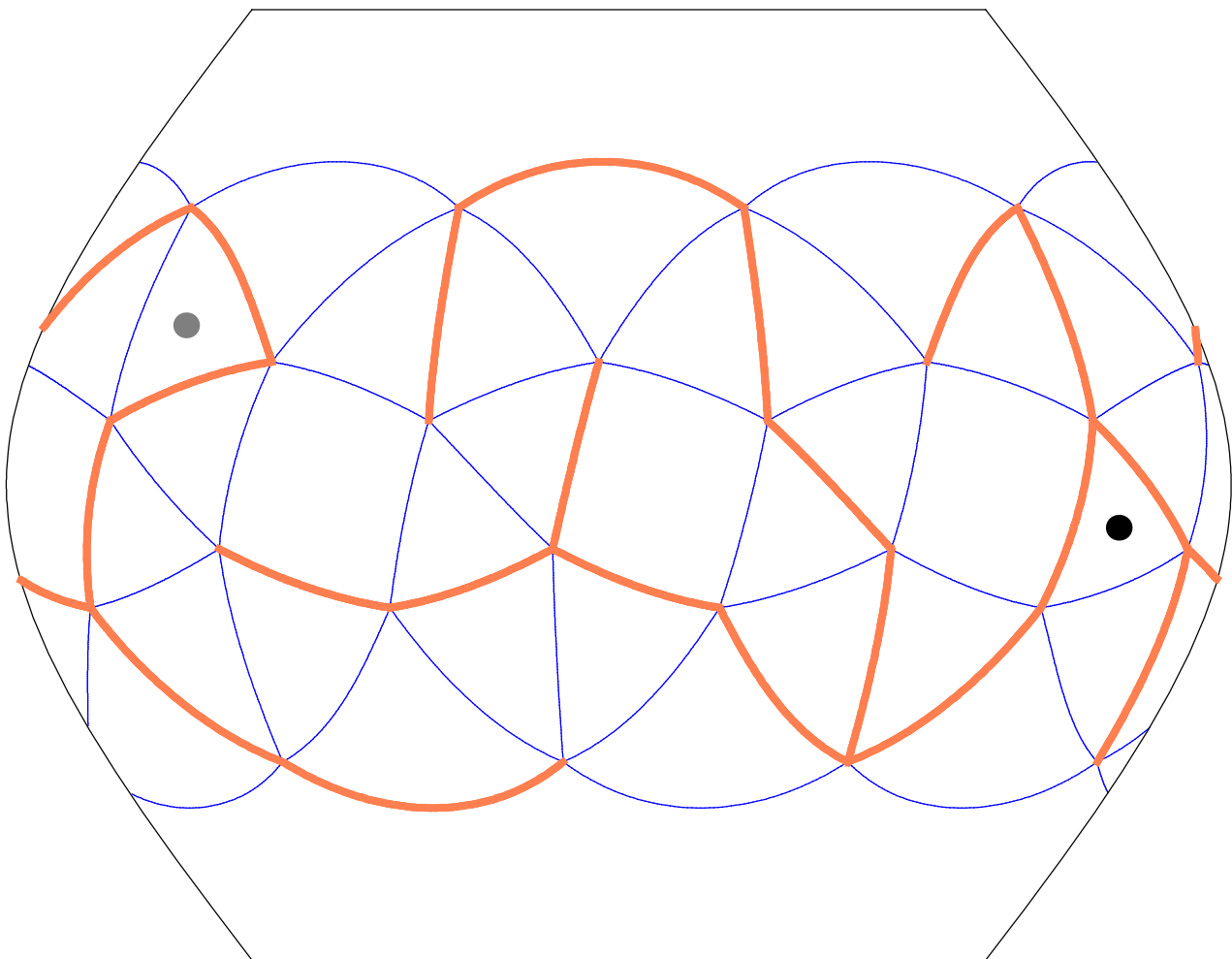
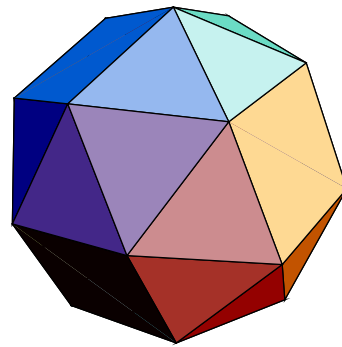
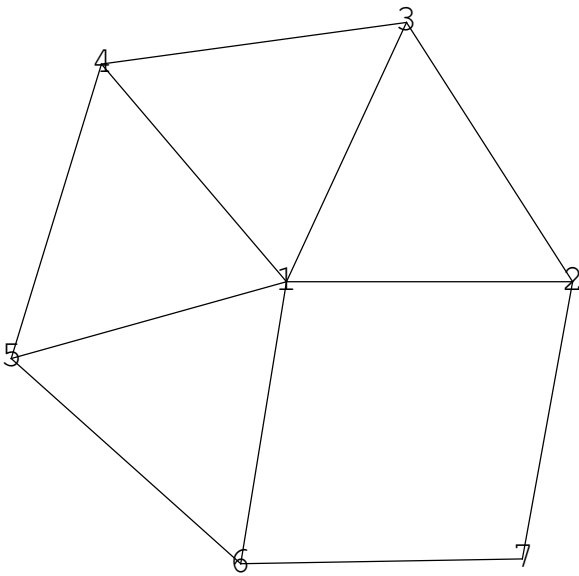

13.

small cubicuboctahedron

$$\left\{8, \frac{3}{2}, 8, 4\right\}$$

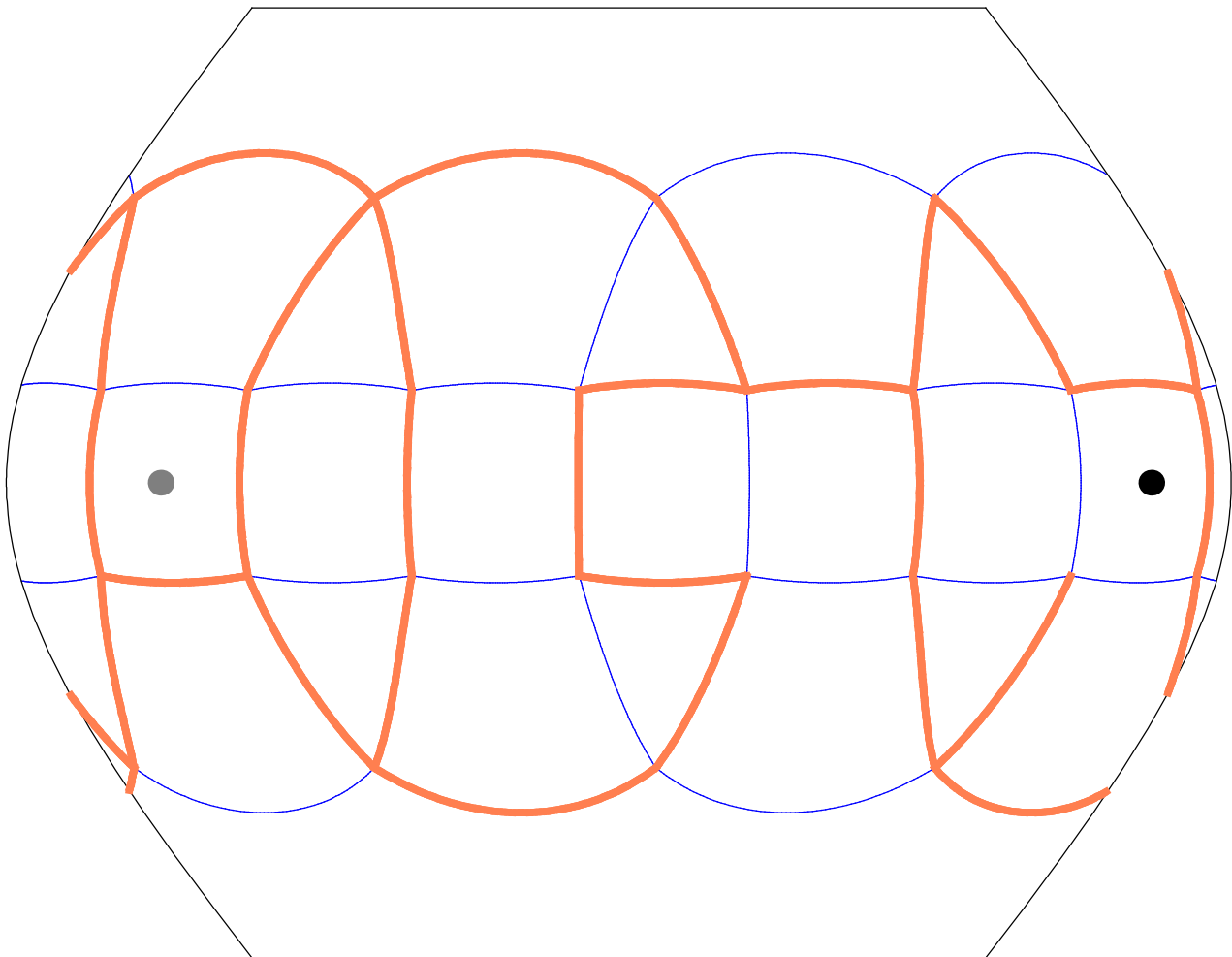
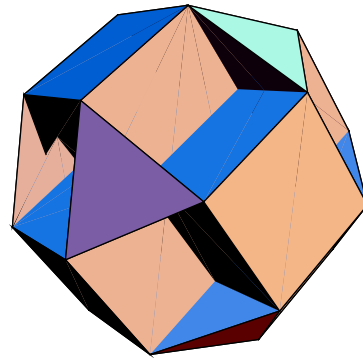
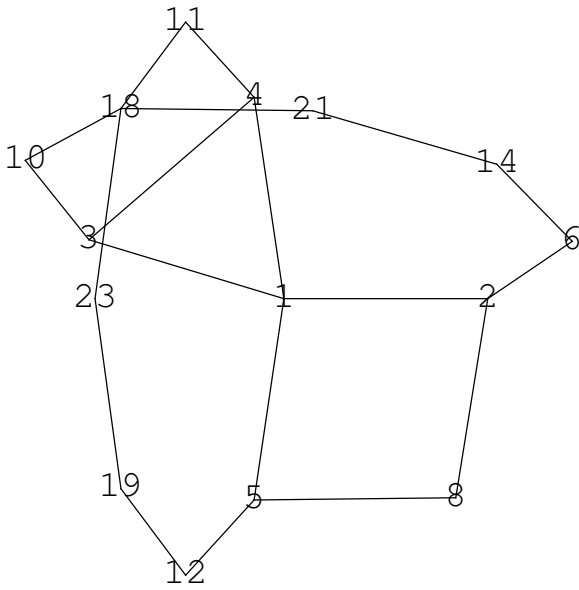

14.

great cubicuboctahedron

$$\left\{ \frac{8}{3}, 3, \frac{8}{3}, 4 \right\}$$

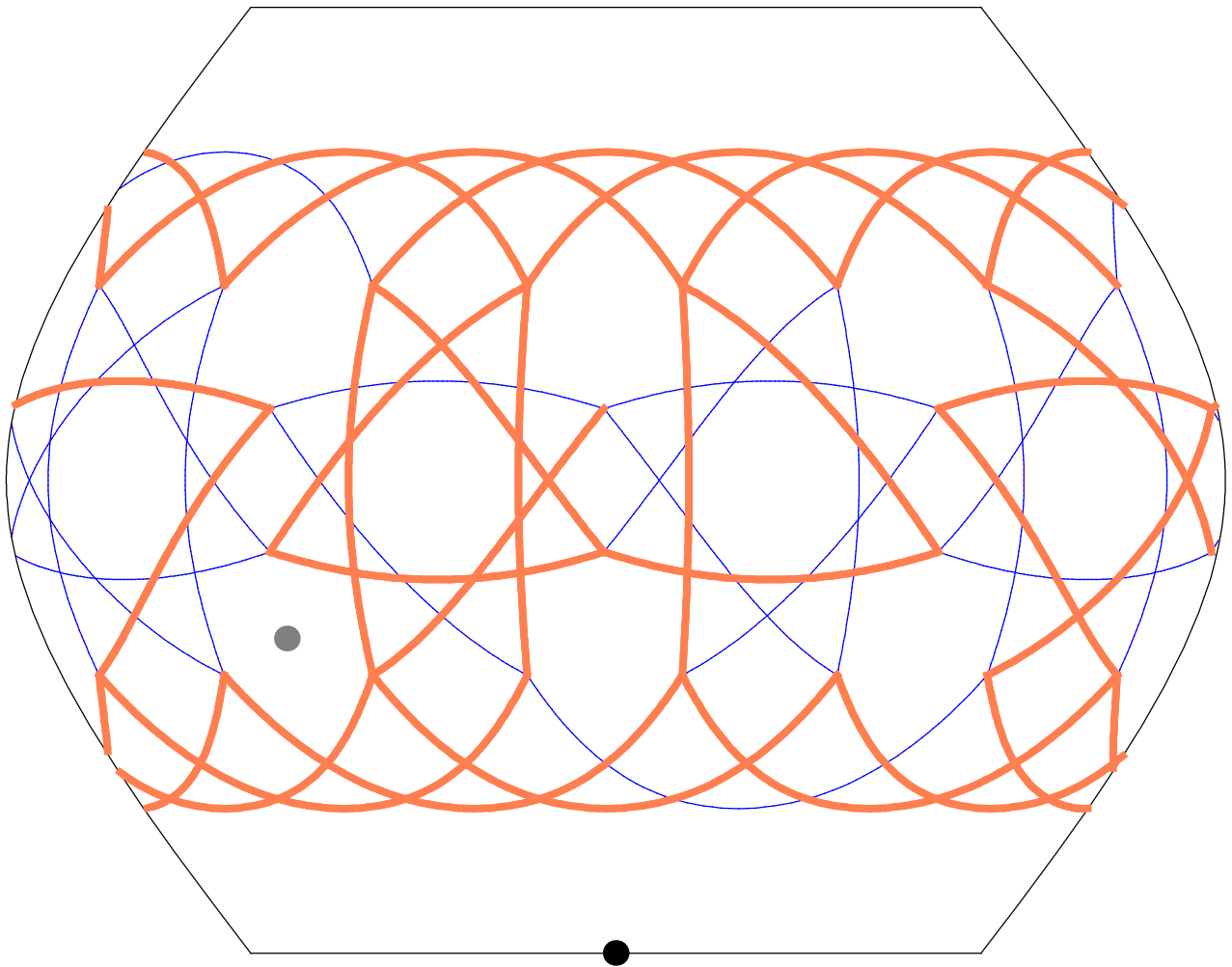
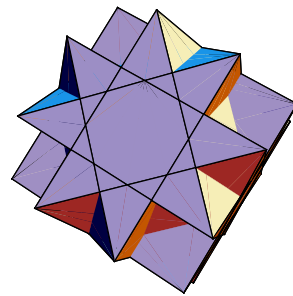
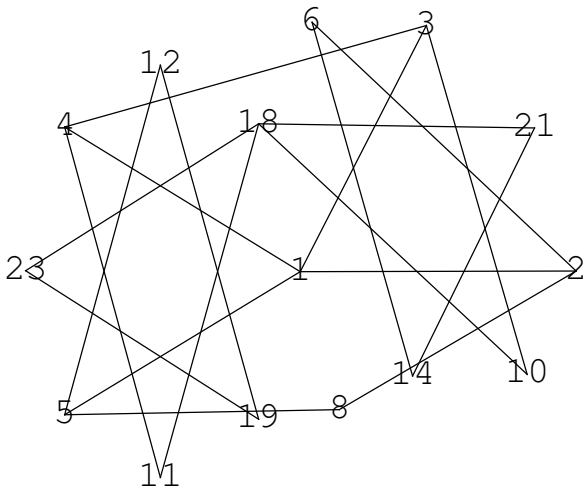

15.

cubohemioctahedron

$$\left\{6, \frac{4}{3}, 6, 4\right\}$$

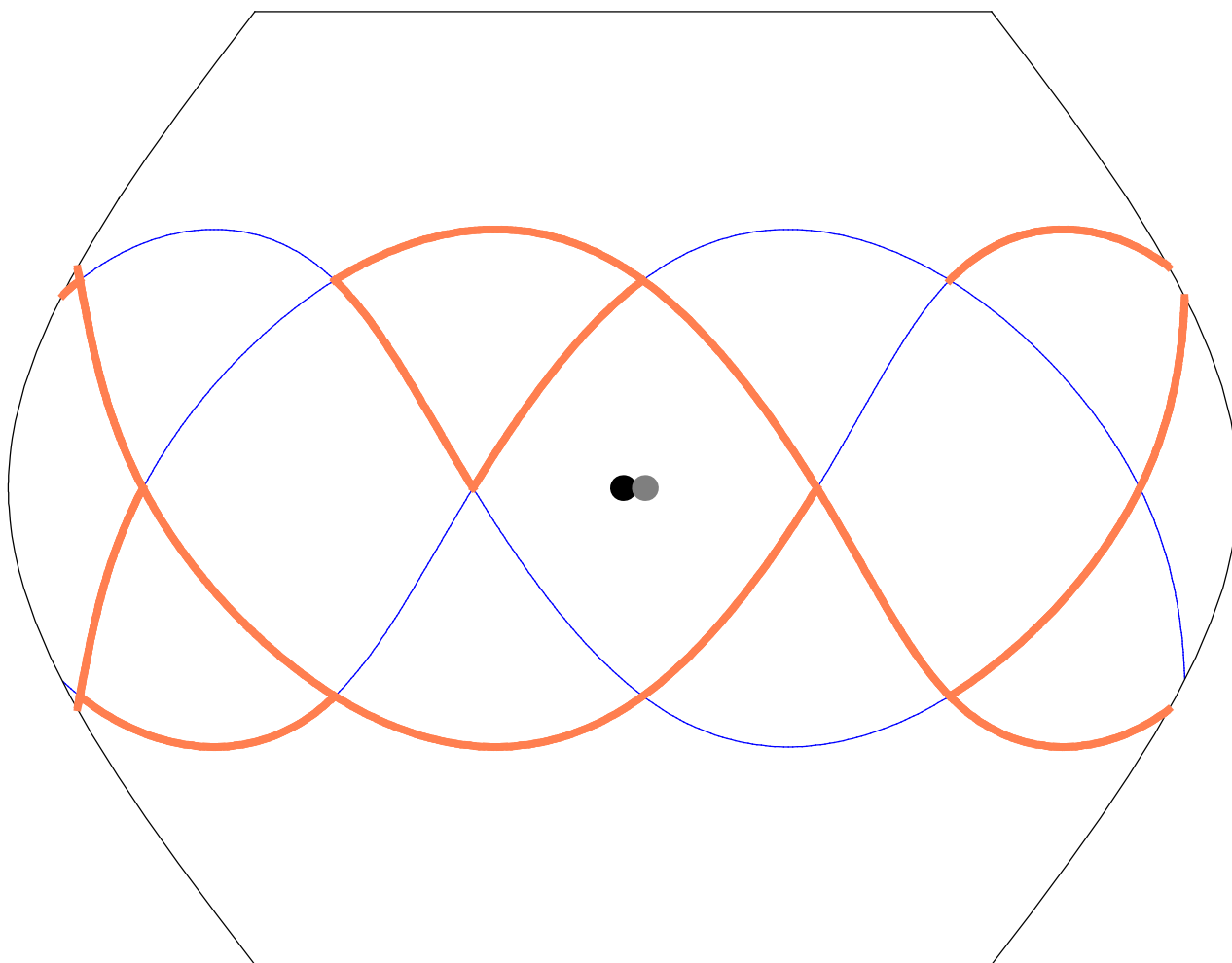
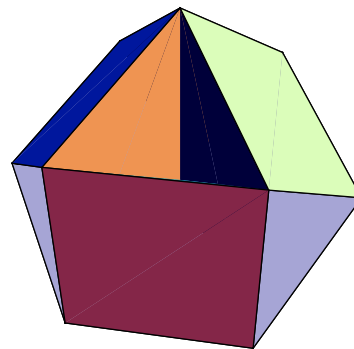
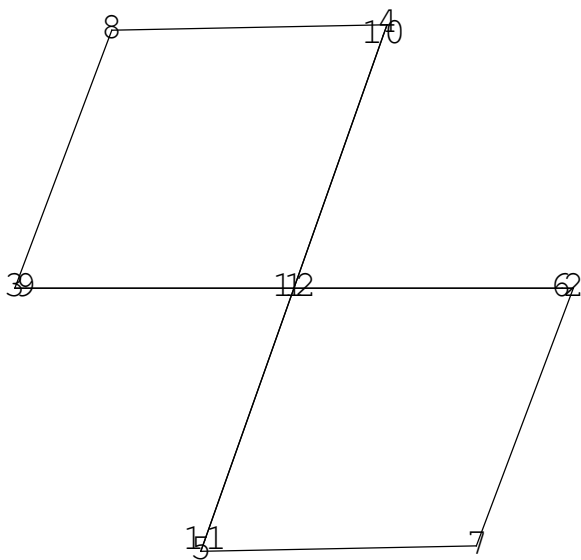

16.

cubitruncated cuboctahedron

$$\left\{ \frac{8}{3}, 6, 8 \right\}$$

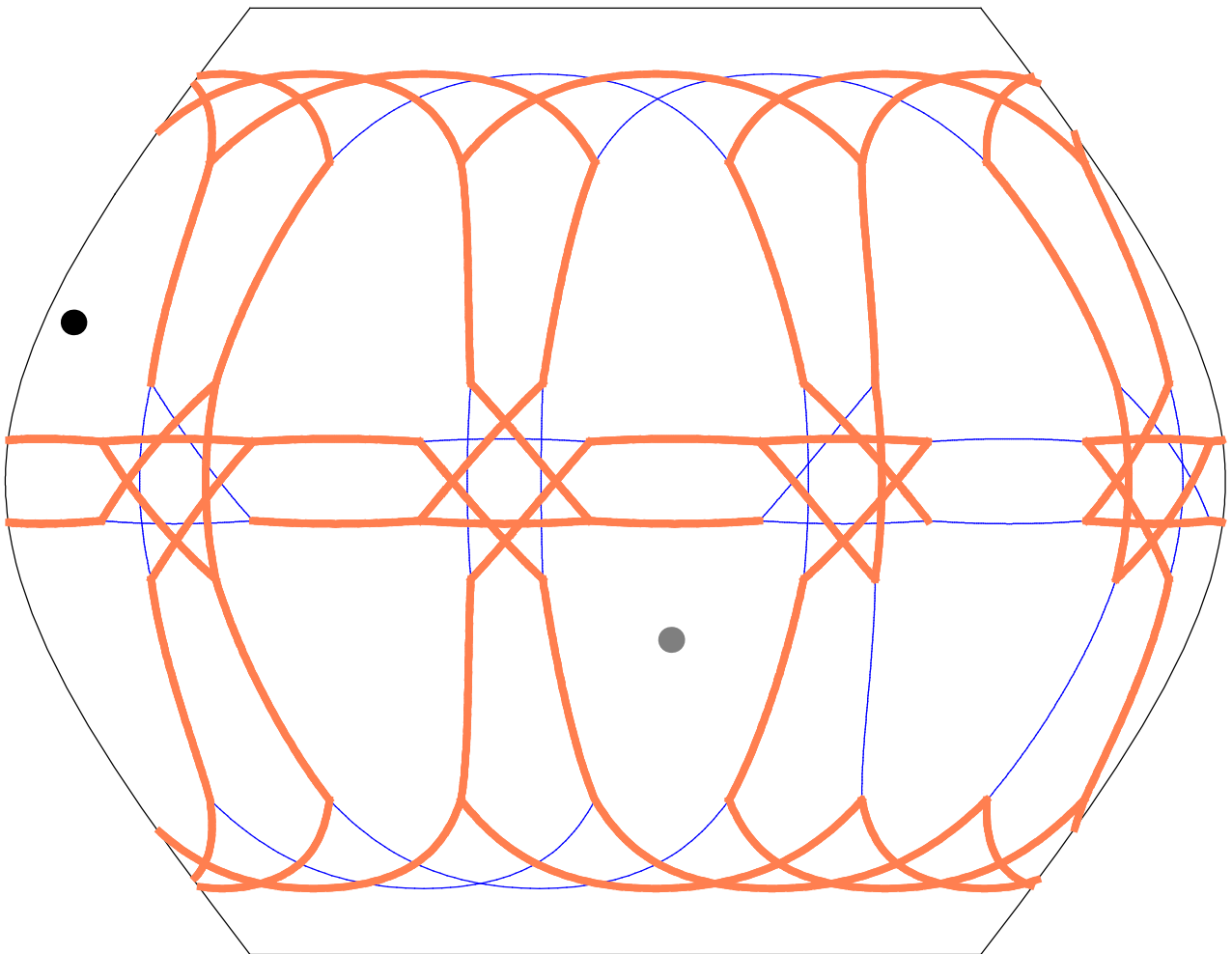
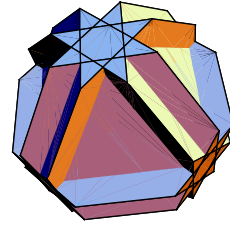
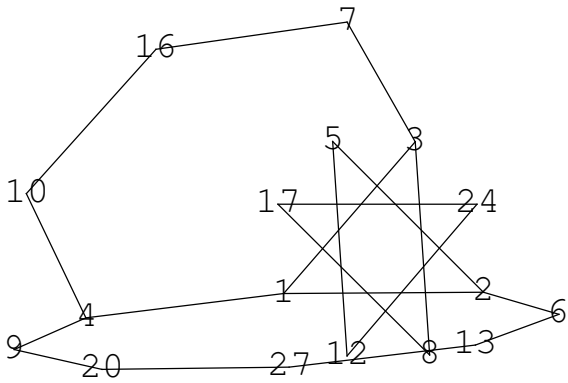

17.

great rhombicuboctahedron

$$\left\{4, \frac{3}{2}, 4, 4\right\}$$

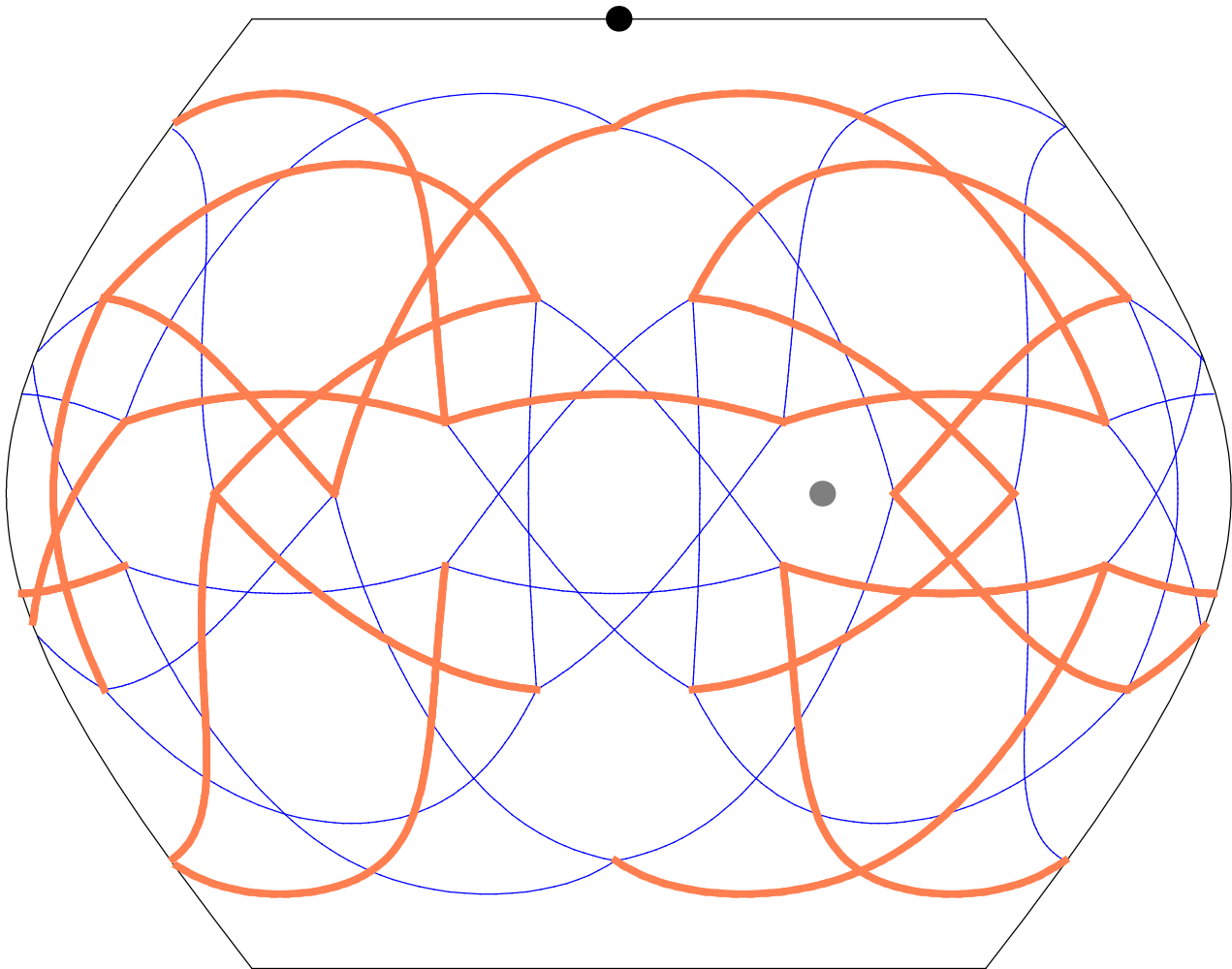
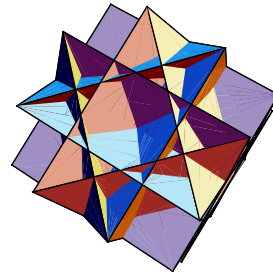
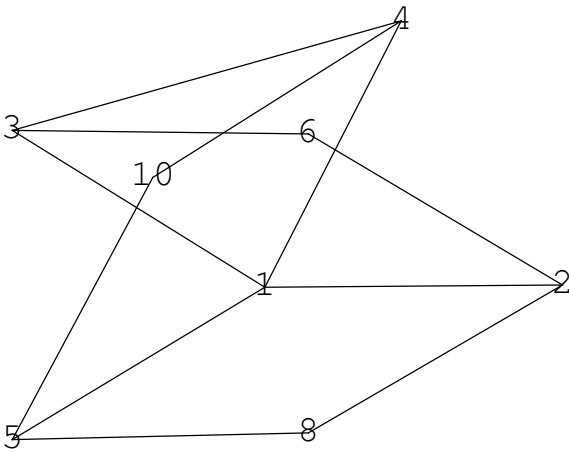

18.

small rhombihexahedron

$$\{8, 4, \frac{8}{7}, \frac{4}{3}\}$$

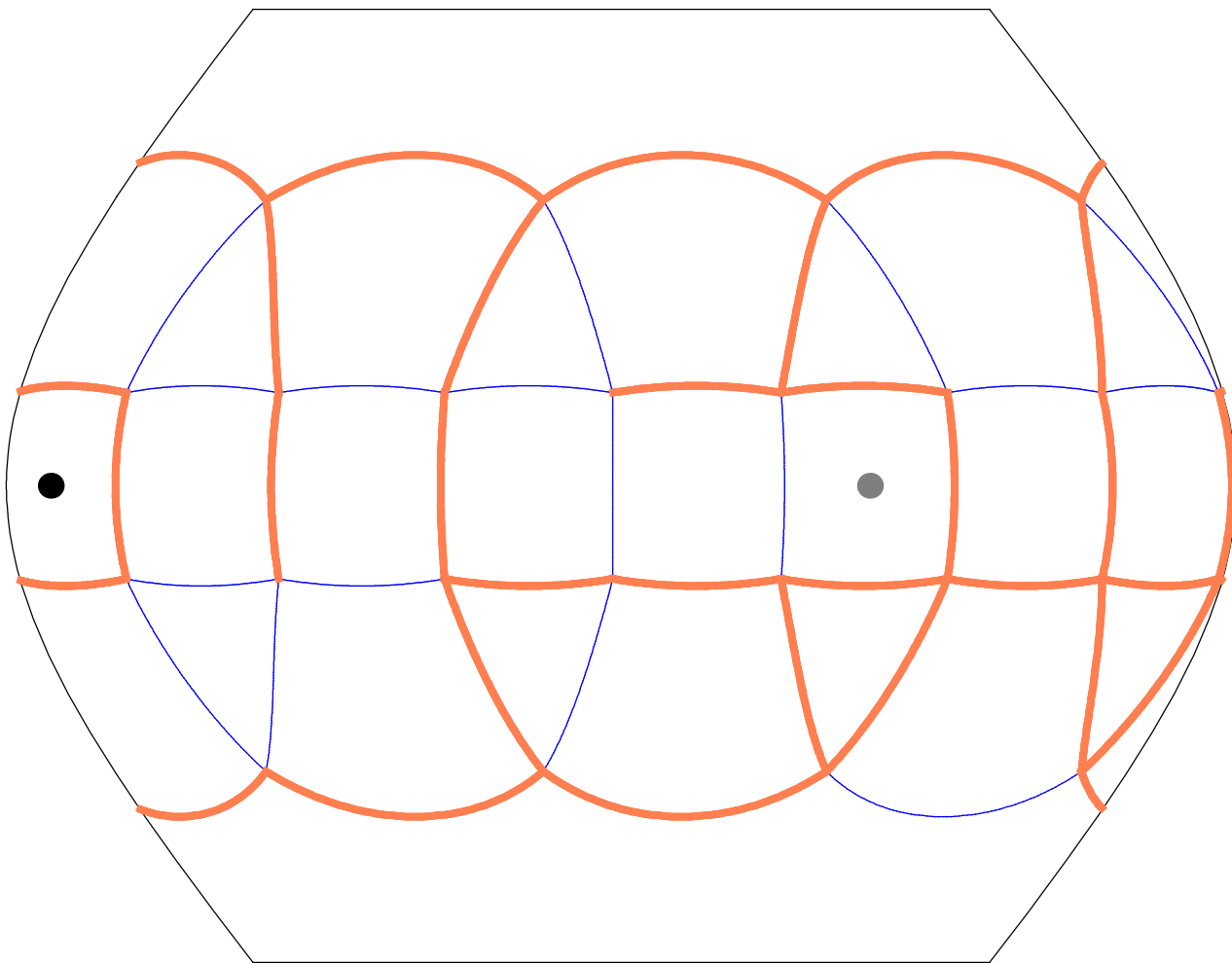
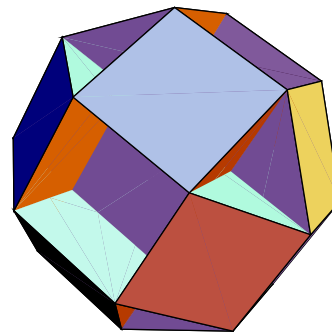
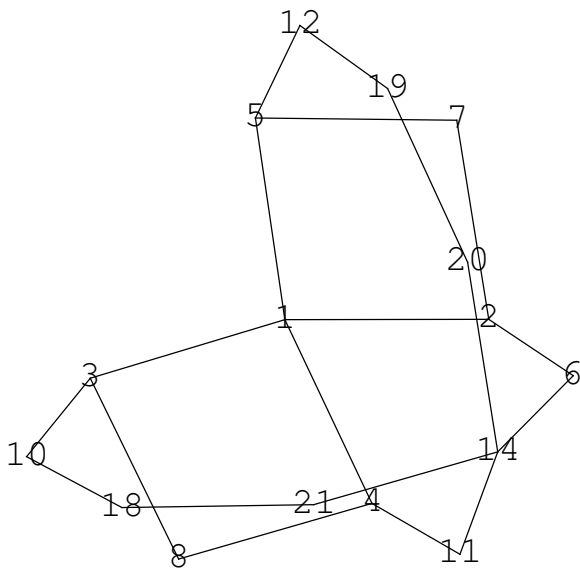

19.

stellated truncated hexahedron

$$\left\{ \frac{8}{3}, \frac{8}{3}, 3 \right\}$$

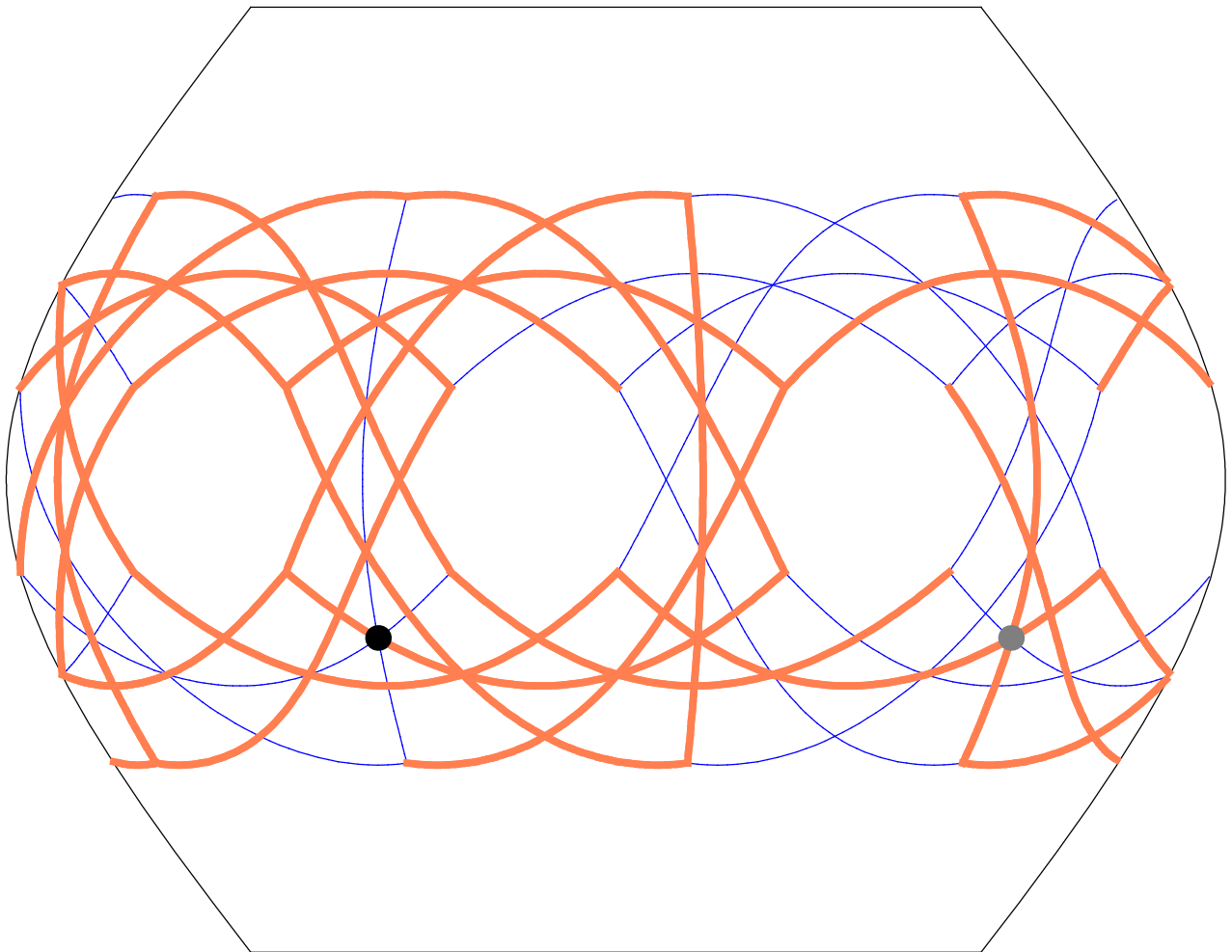
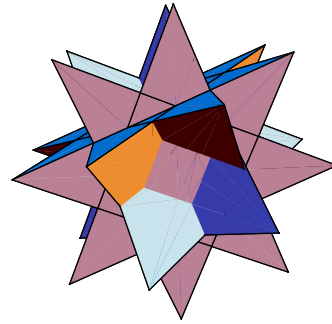
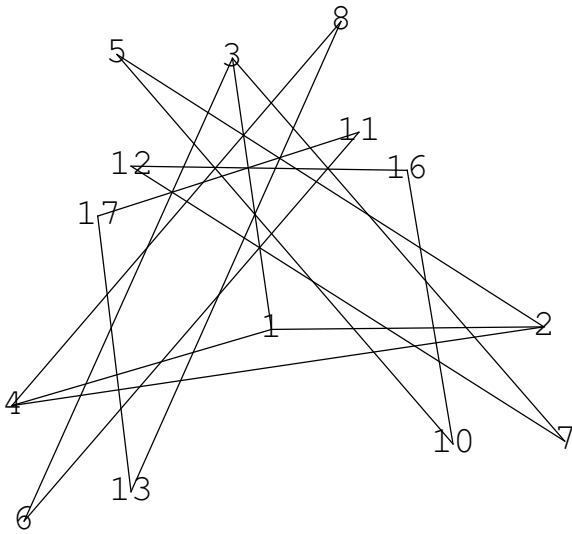

20.

great truncated cuboctahedron

$$\left\{ \frac{8}{3}, 4, 6 \right\}$$

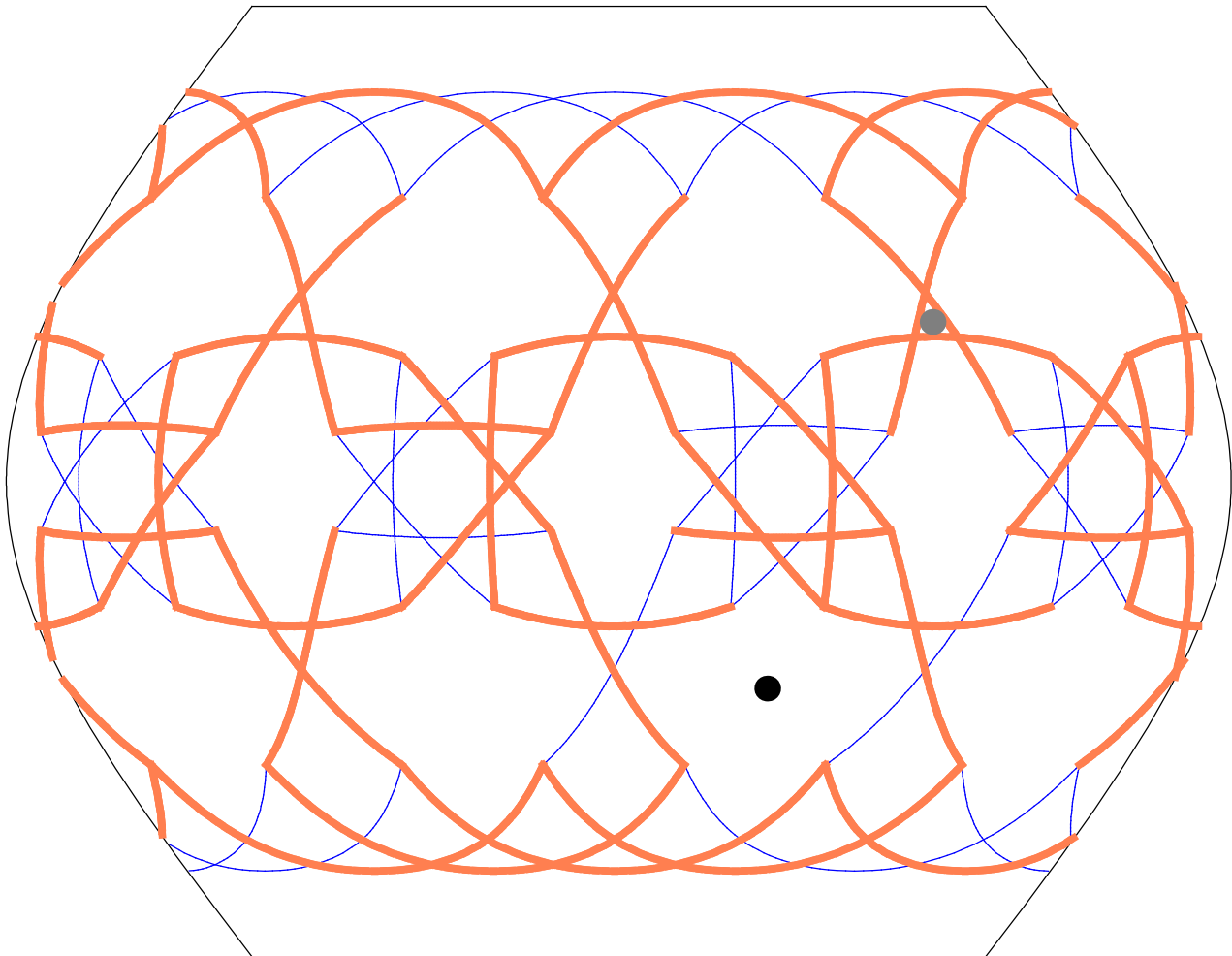
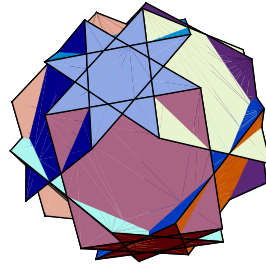
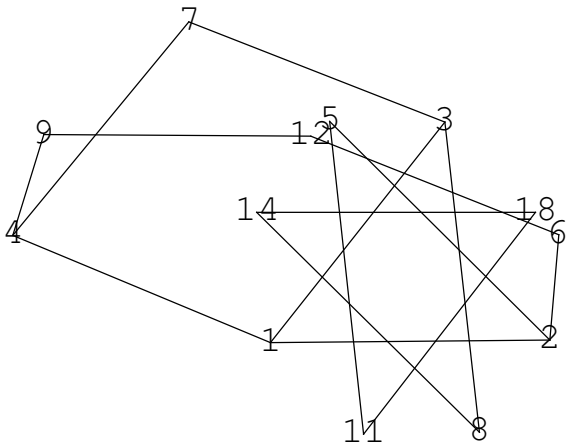

21.

great rhombihexahedron

$$\left\{4, \frac{8}{3}, \frac{4}{3}, \frac{8}{5}\right\}$$

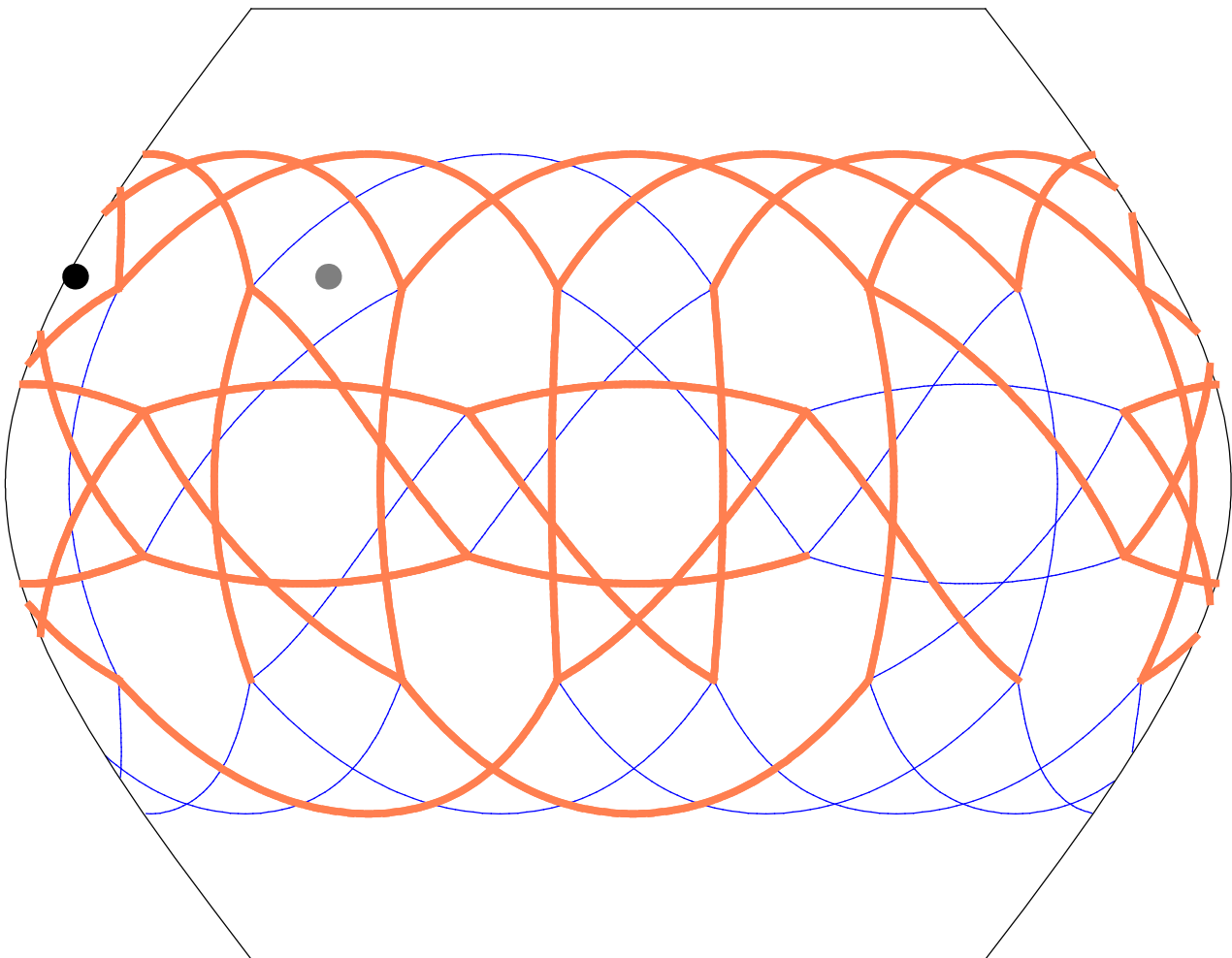
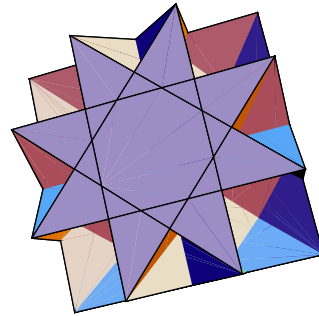
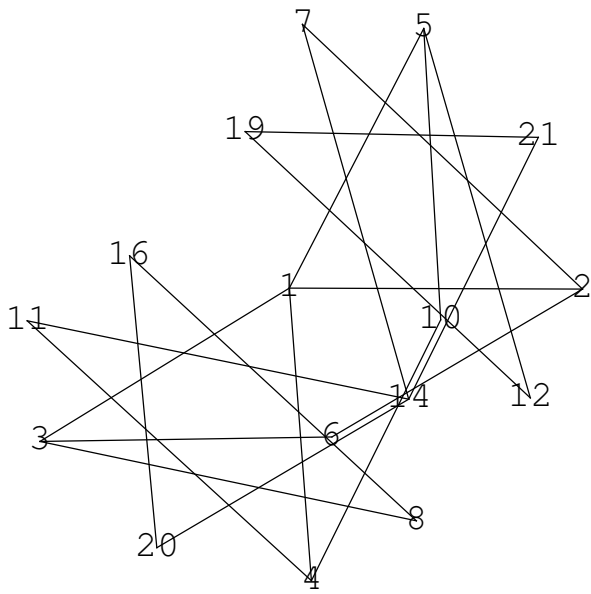

22.

icosahedron

{3, 3, 3, 3, 3}

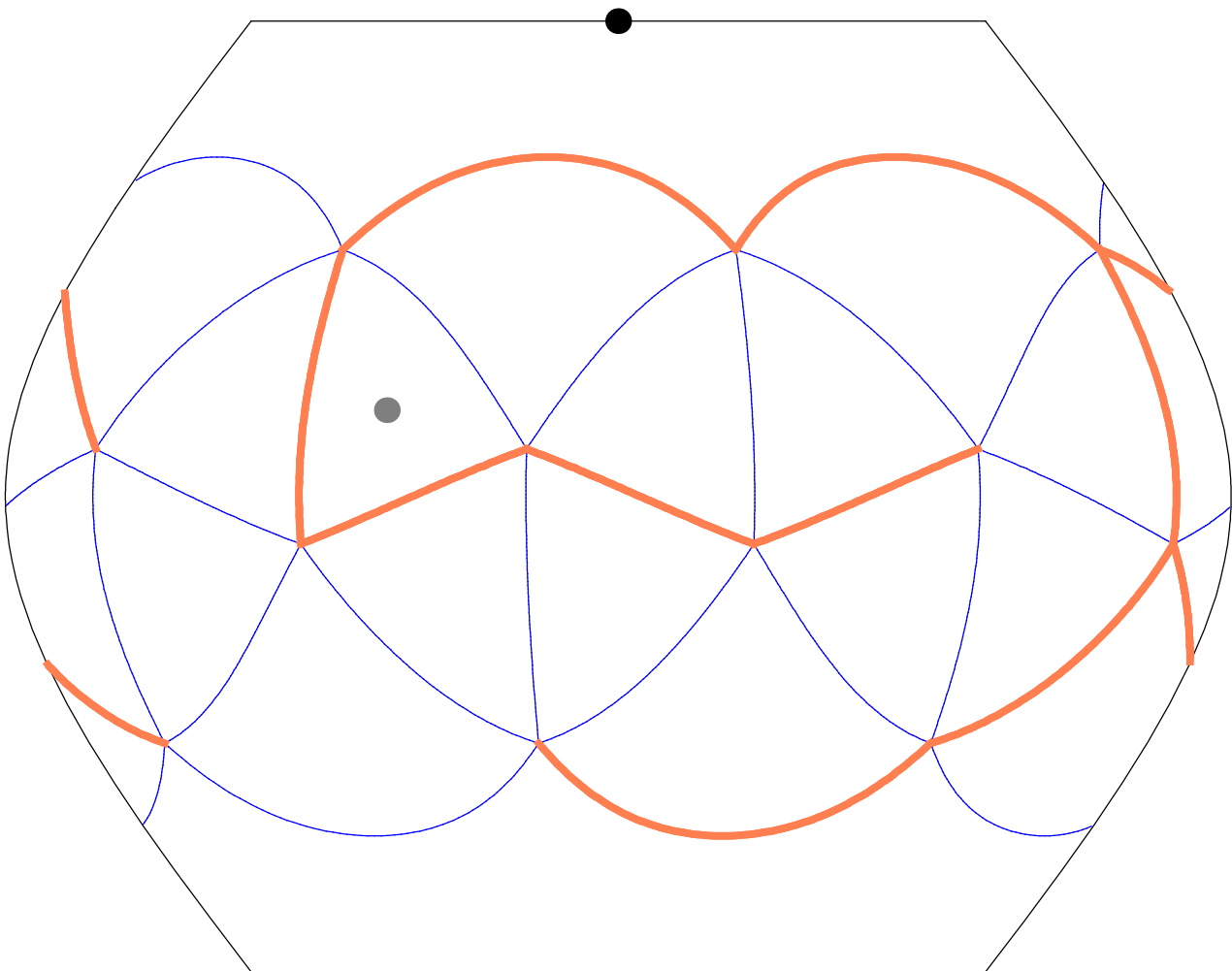
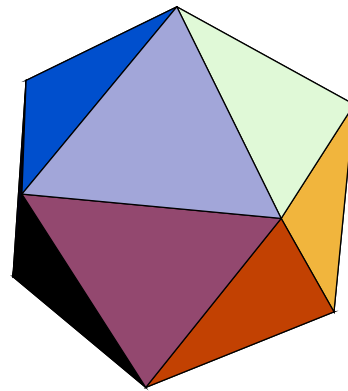
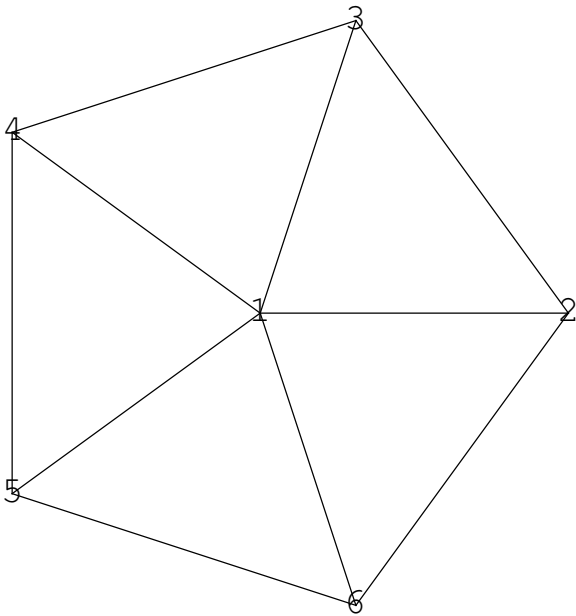

23.

dodecahedron

{5, 5, 5}

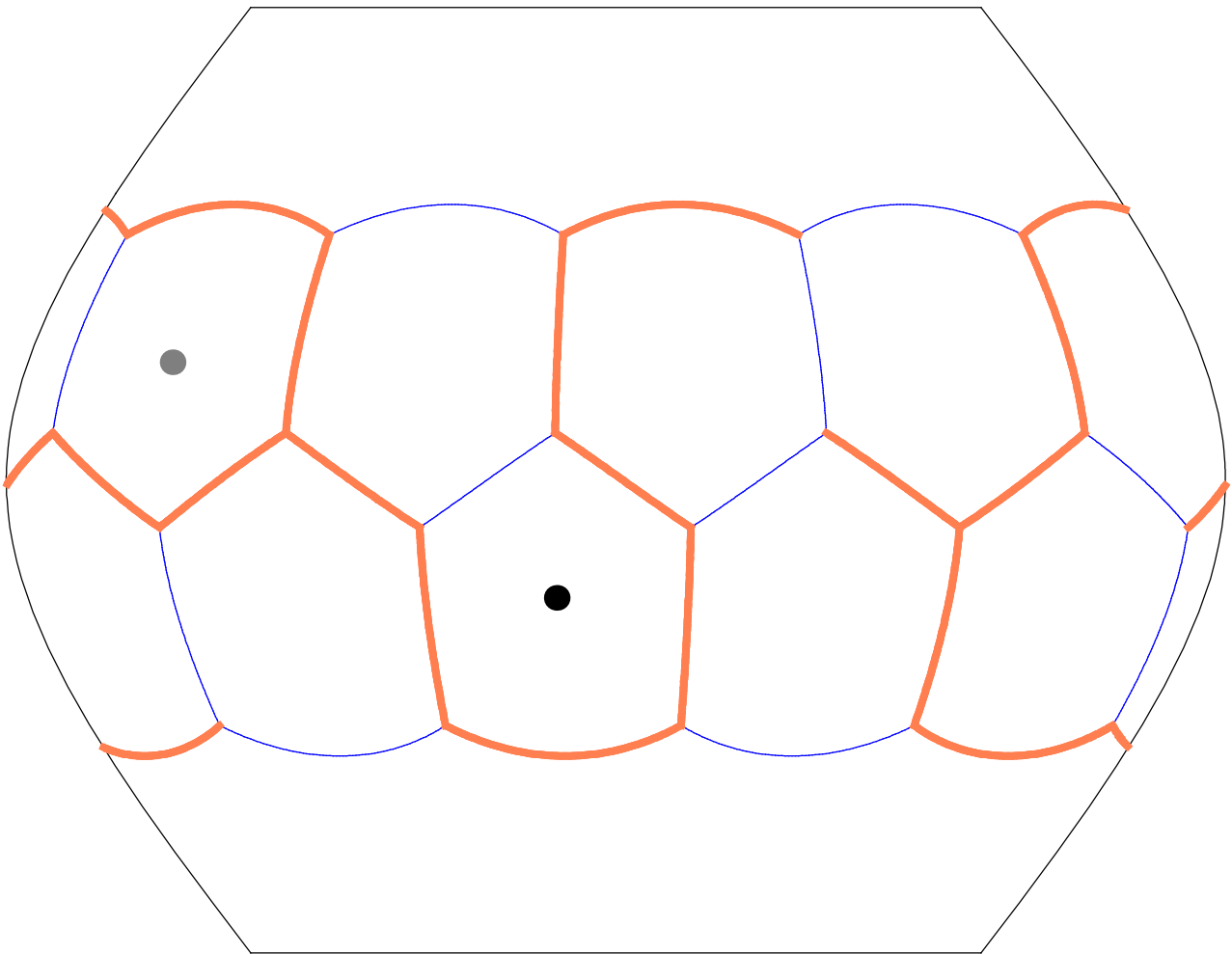
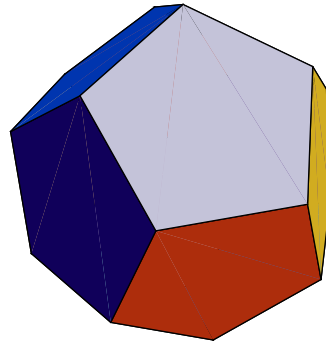
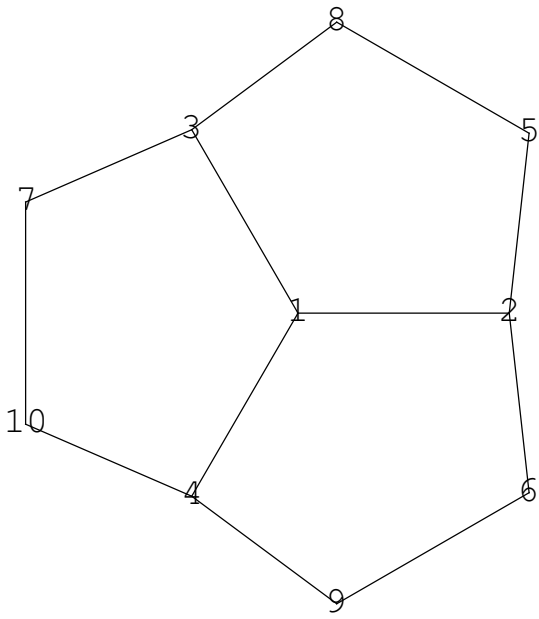

24.

icosidodecahedron

{3, 5, 3, 5}

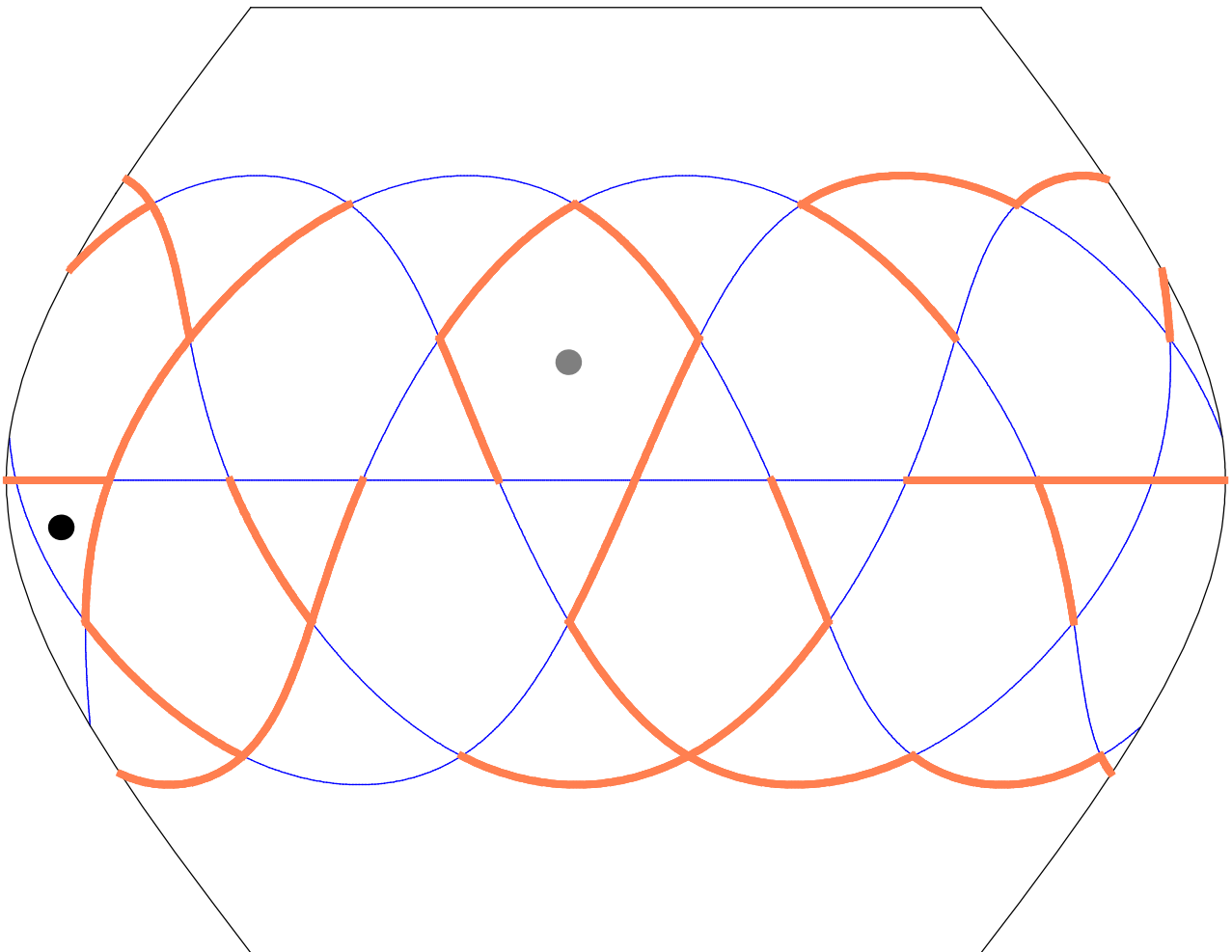
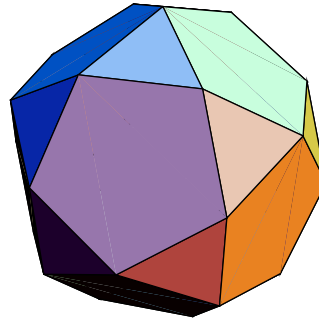
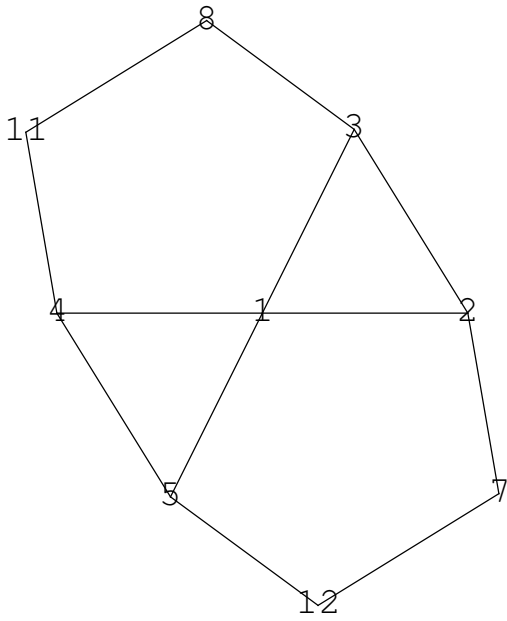

25.

truncated icosahedron

{6, 6, 5}

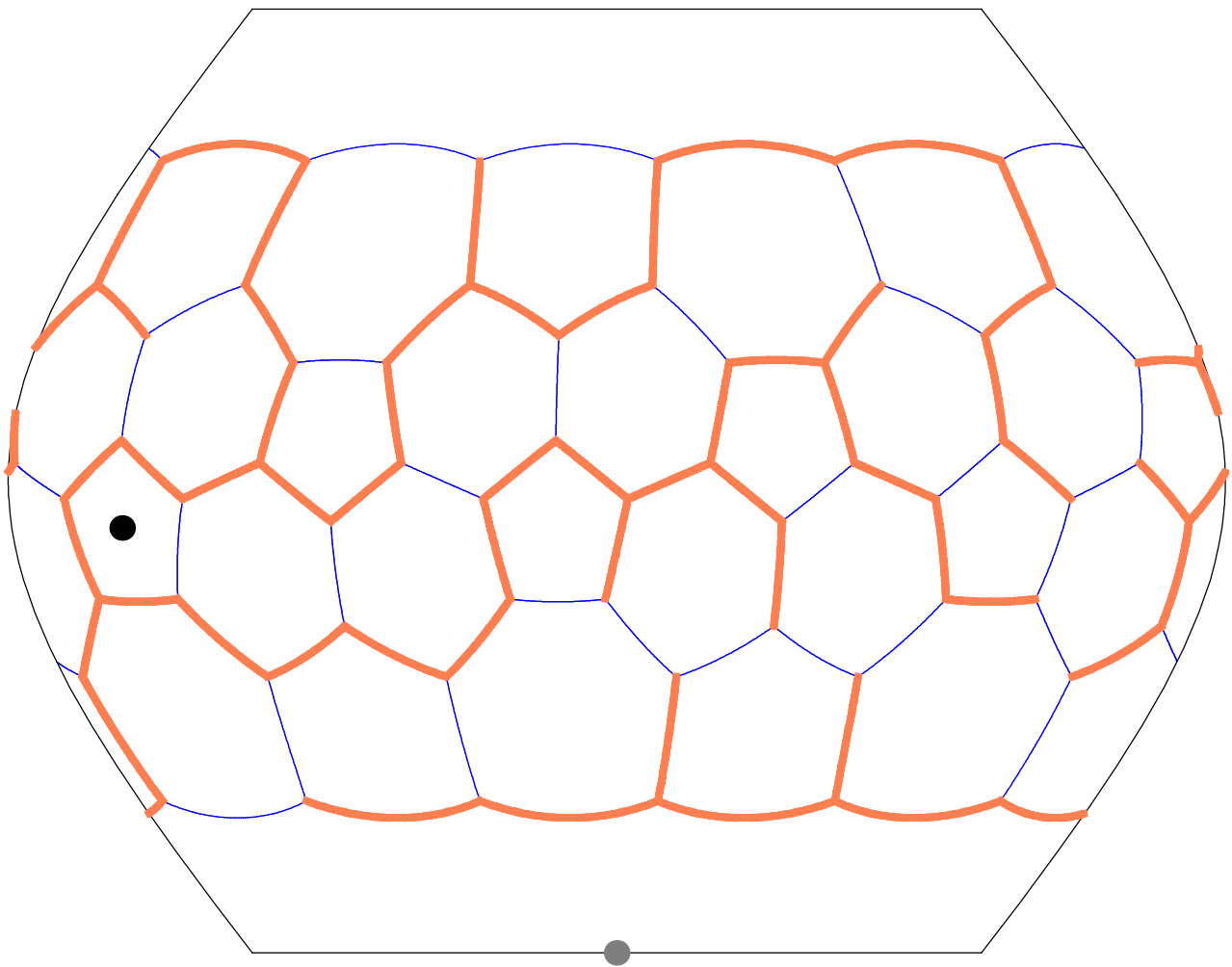
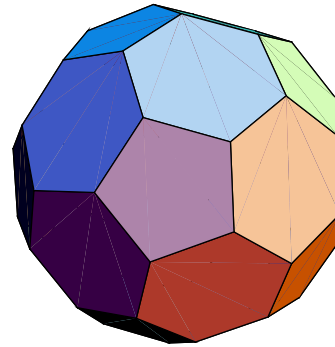
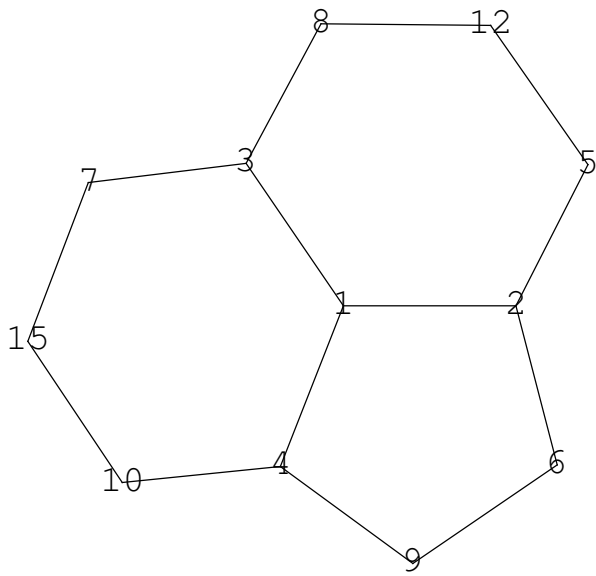

26.

truncated dodecahedron

{10, 10, 3}

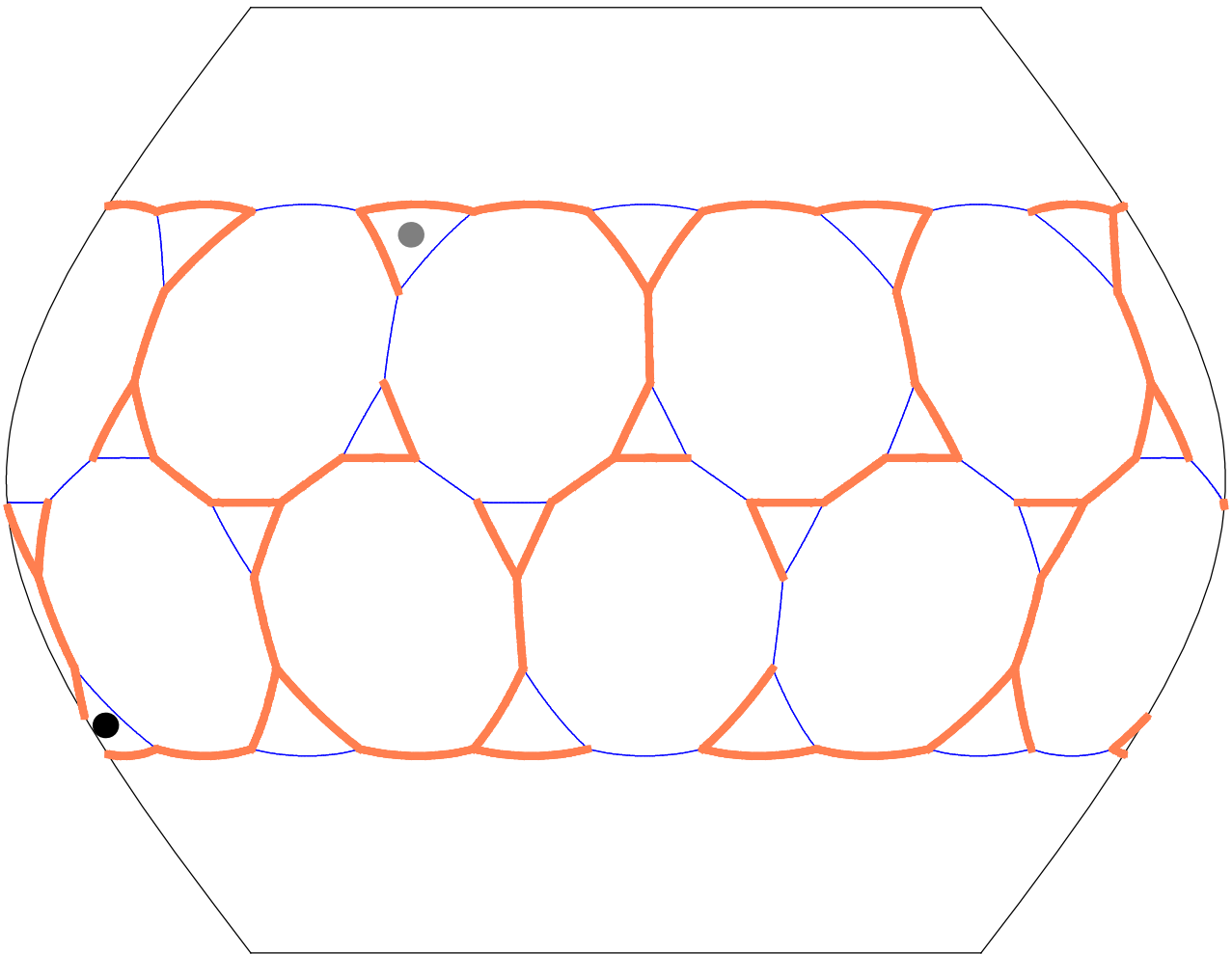
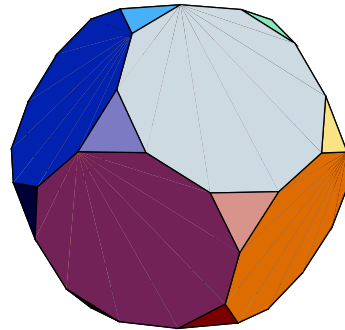
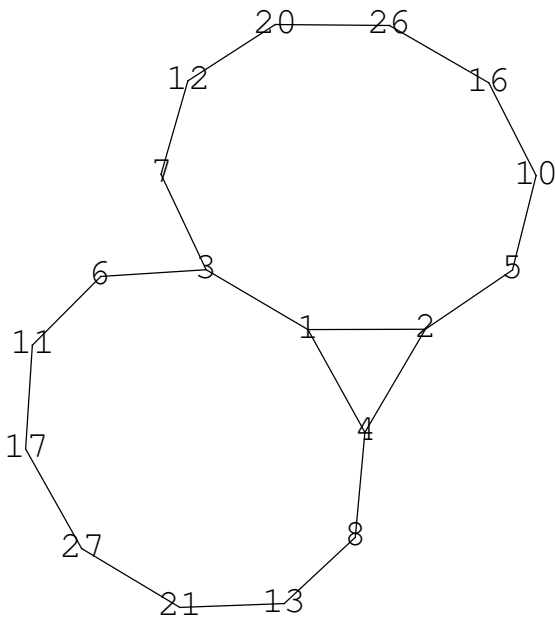

27.

rhombicosidodecahedron

{4, 3, 4, 5}

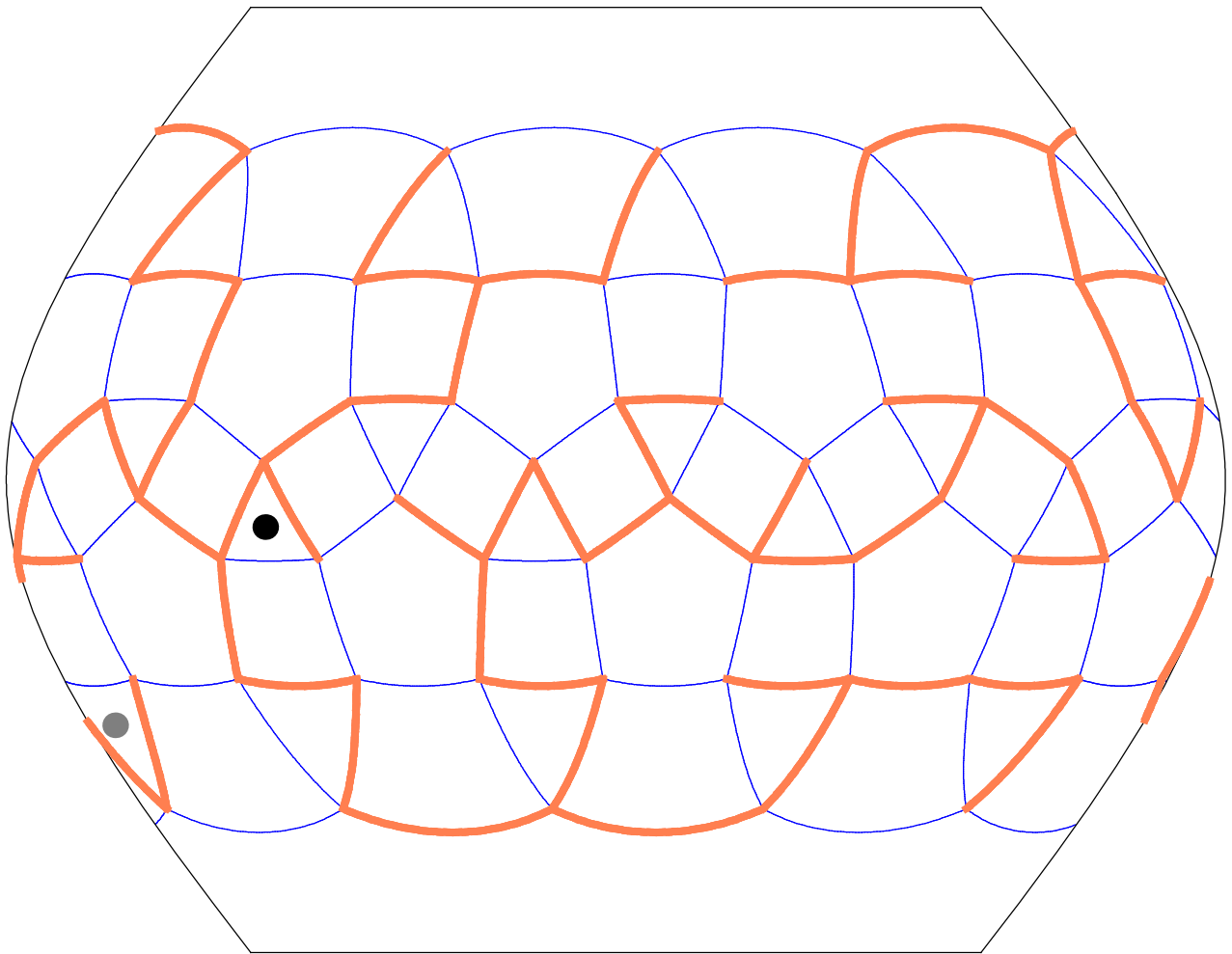
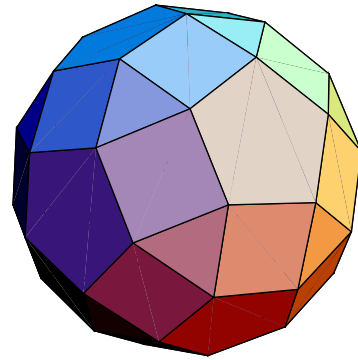
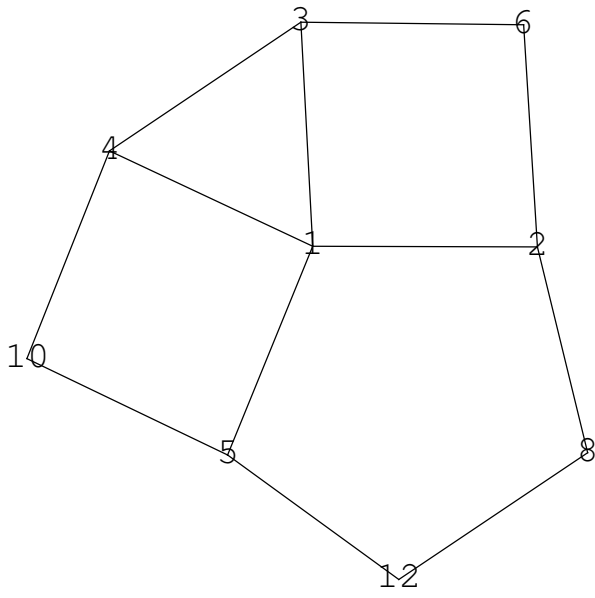

28.

truncated icosidodecahedron

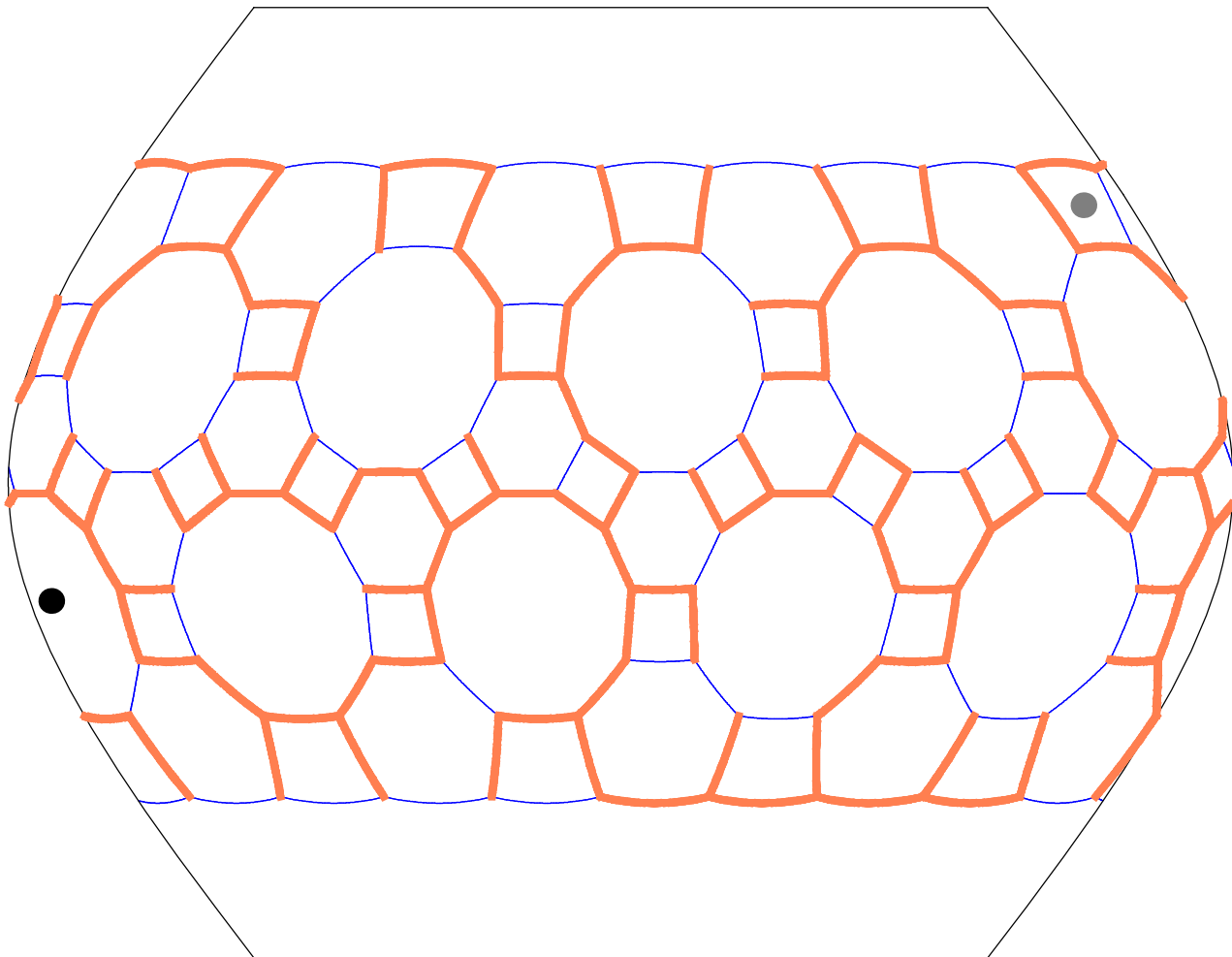
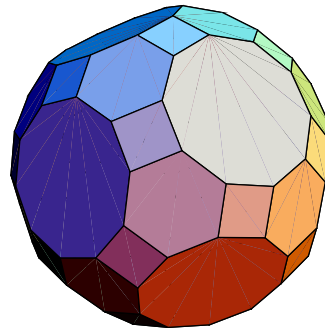
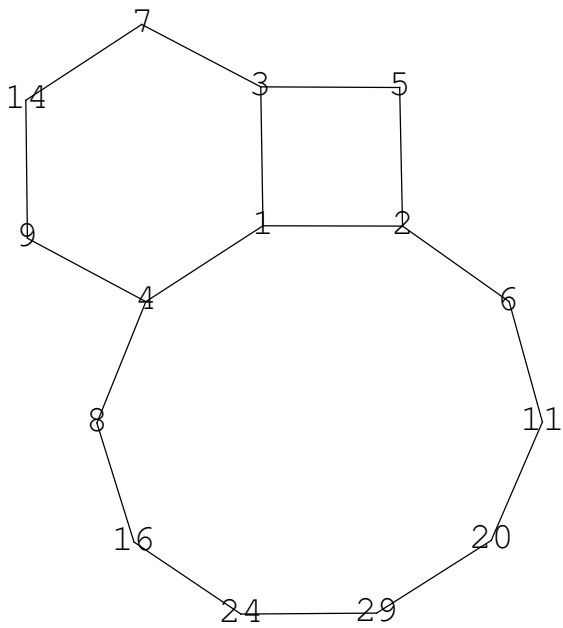
 $\{4, 6, 10\}$ 

29.

snub dodecahedron

{3, 3, 3, 3, 5}

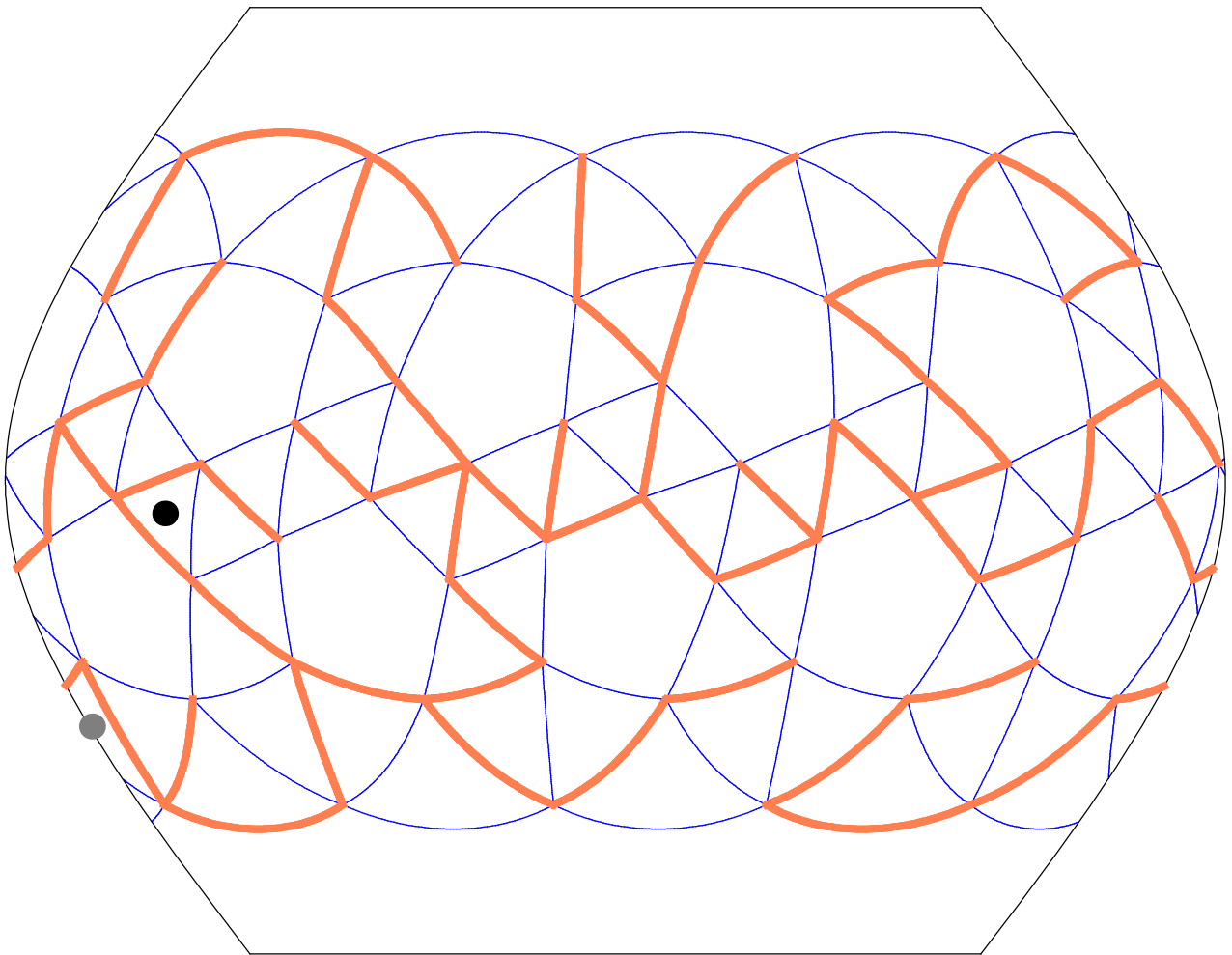
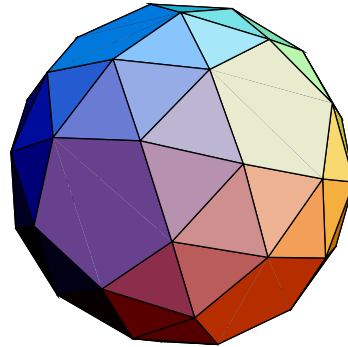
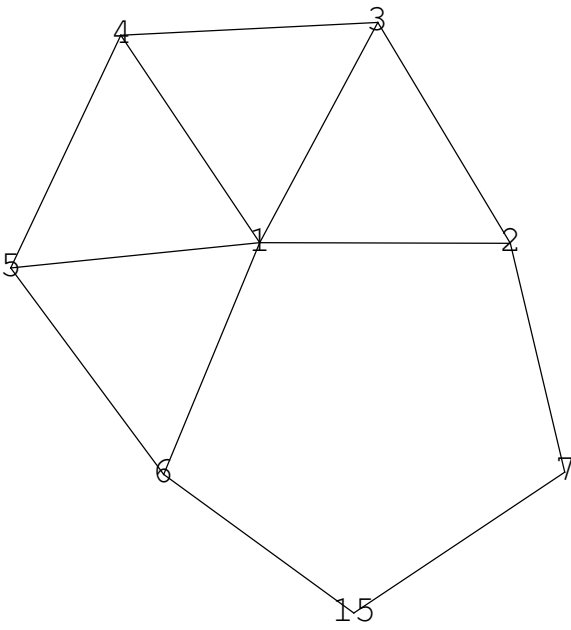

Solutions

1.

tetrahedron

{3, 3, 3}

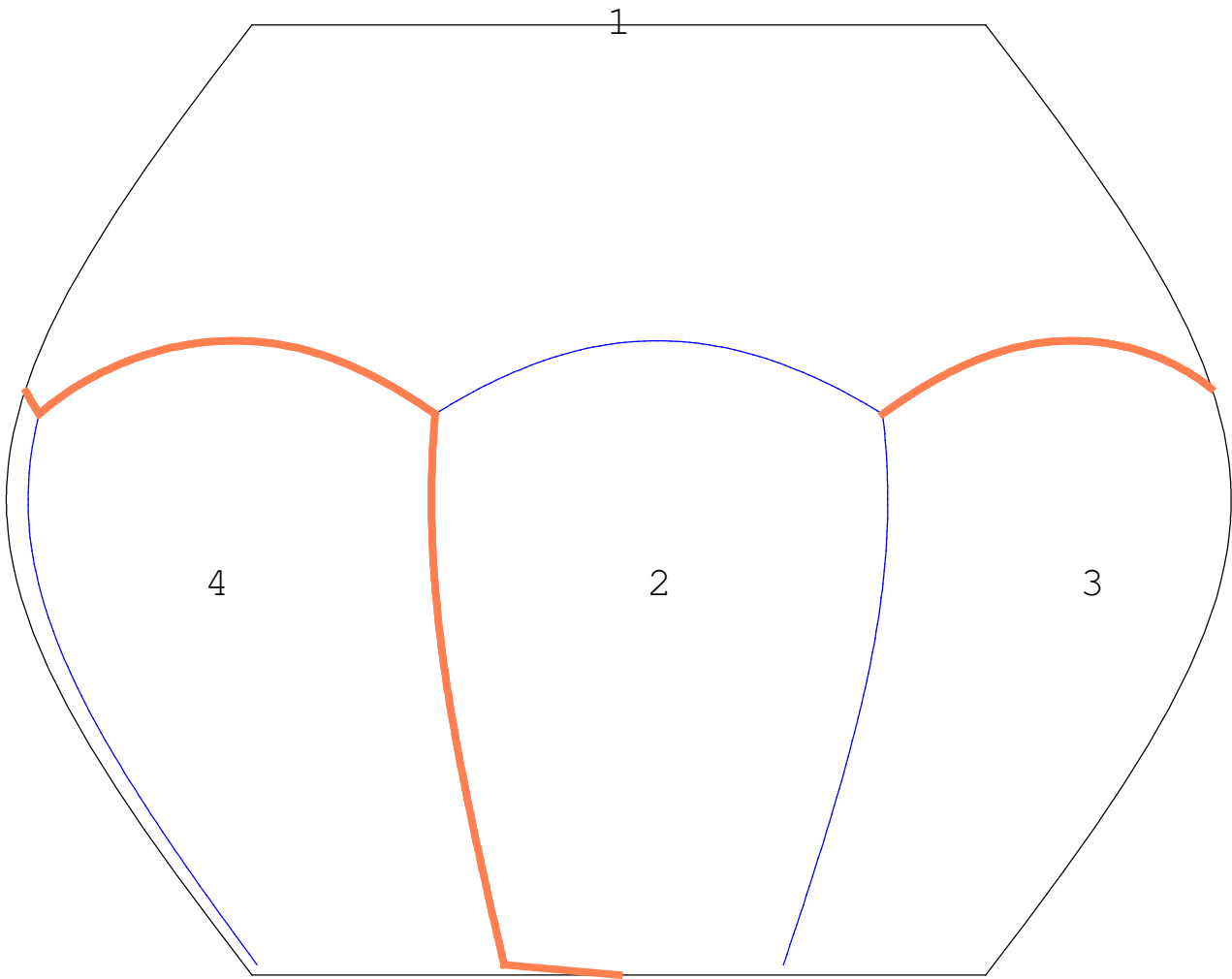
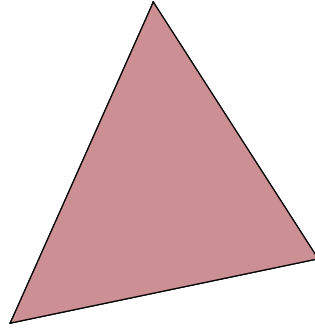
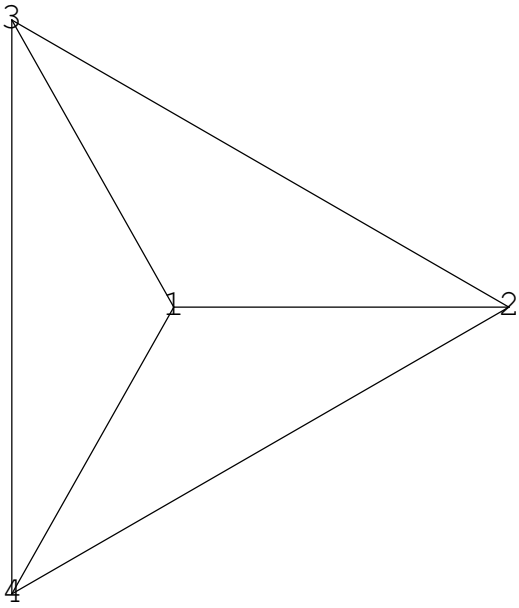

2.

truncated tetrahedron

{6, 6, 3}

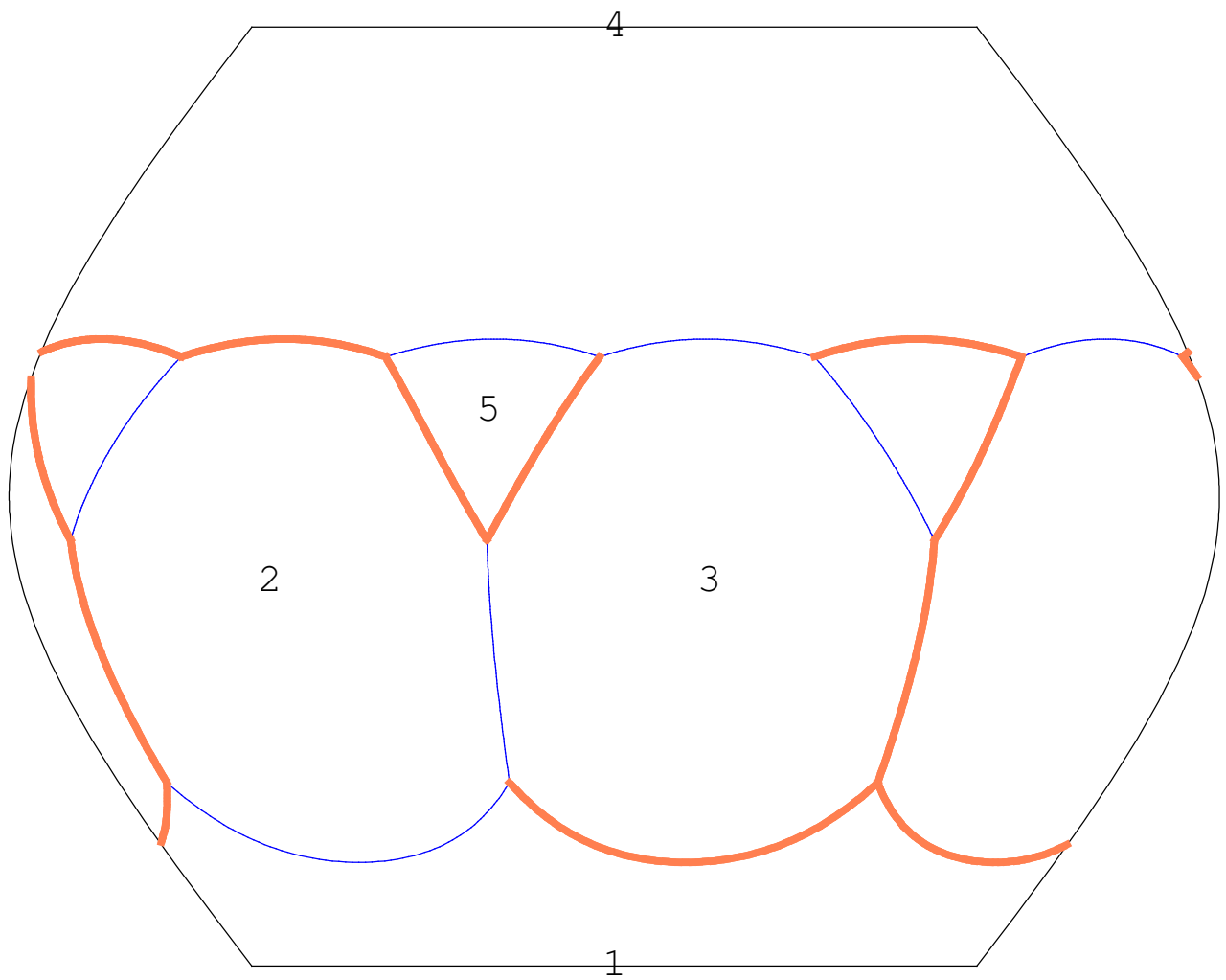
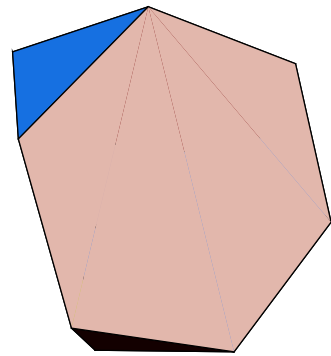
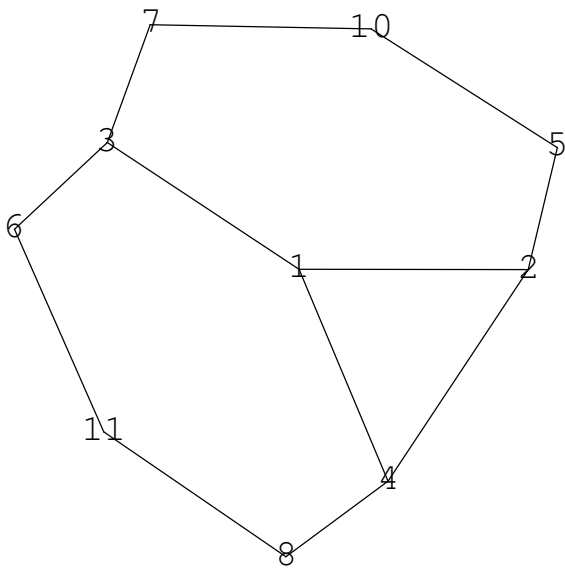

3.

octahemioctahedron

$$\{6, \frac{3}{2}, 6, 3\}$$

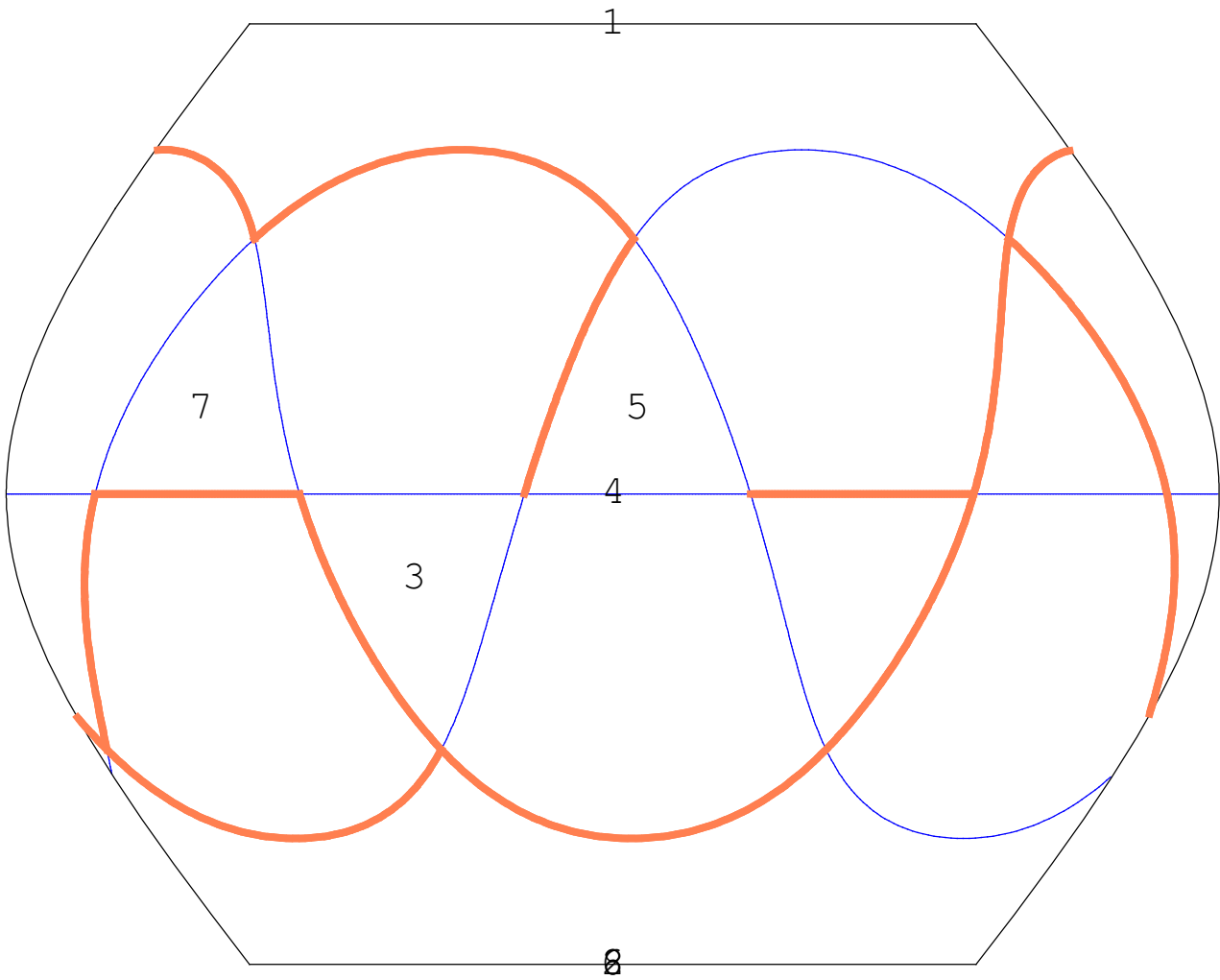
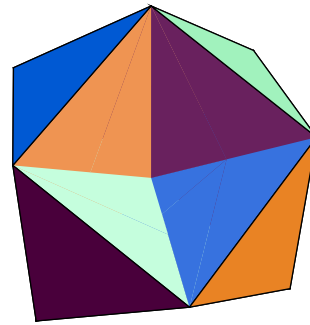
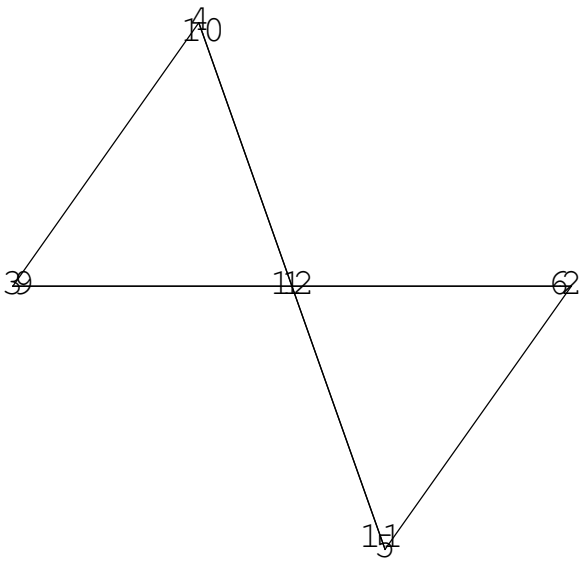

4.

tetrahemihexahedron

$$\{4, \frac{3}{2}, 4, 3\}$$

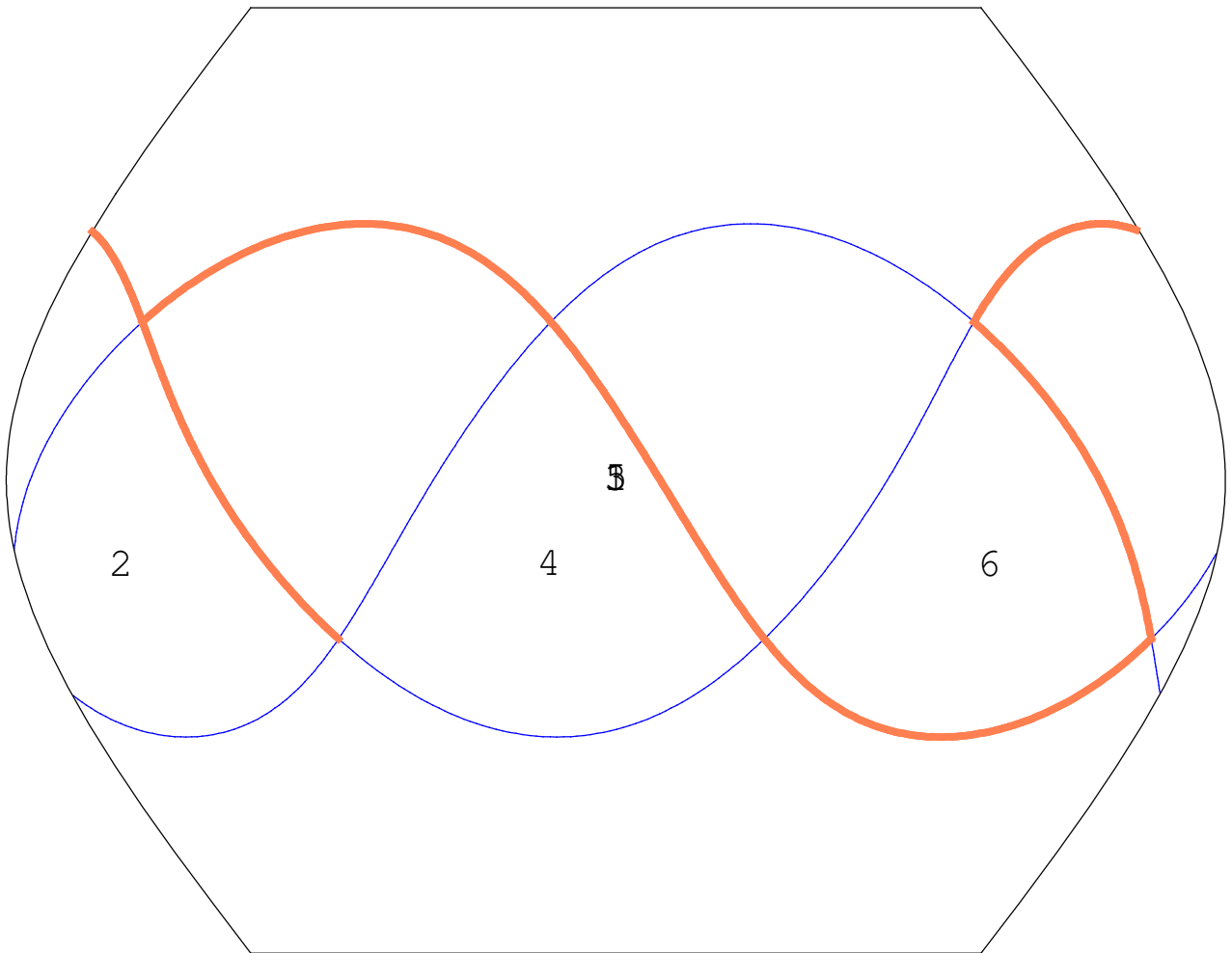
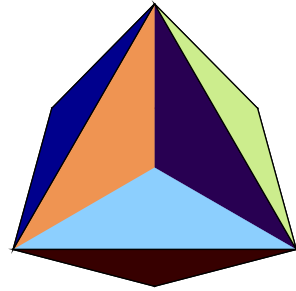
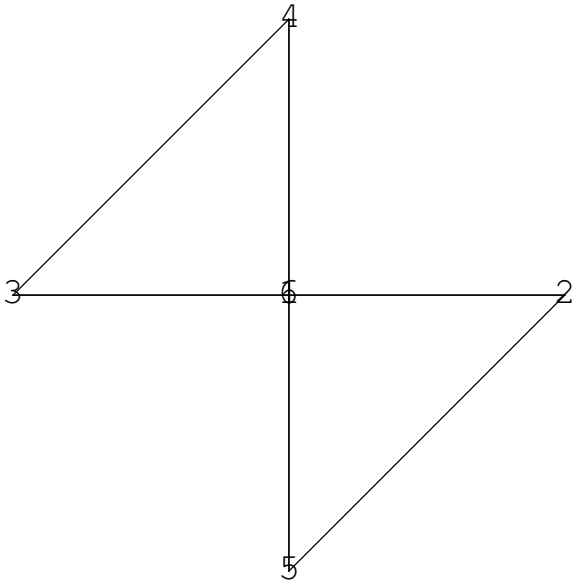

5.

octahedron

{3, 3, 3, 3}

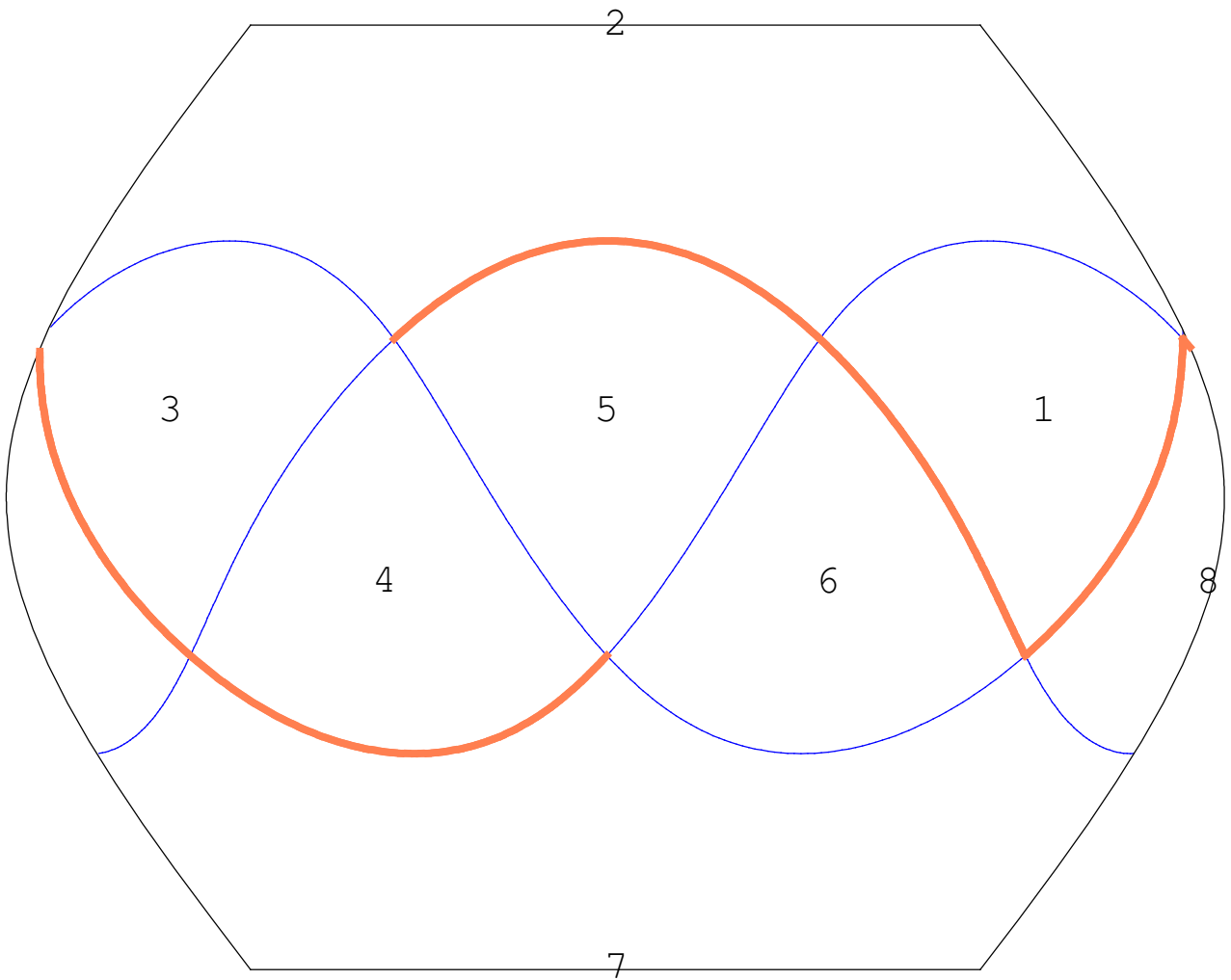
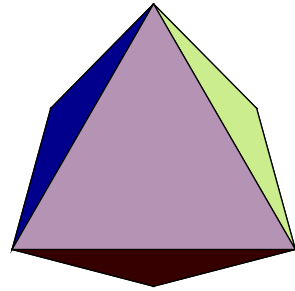
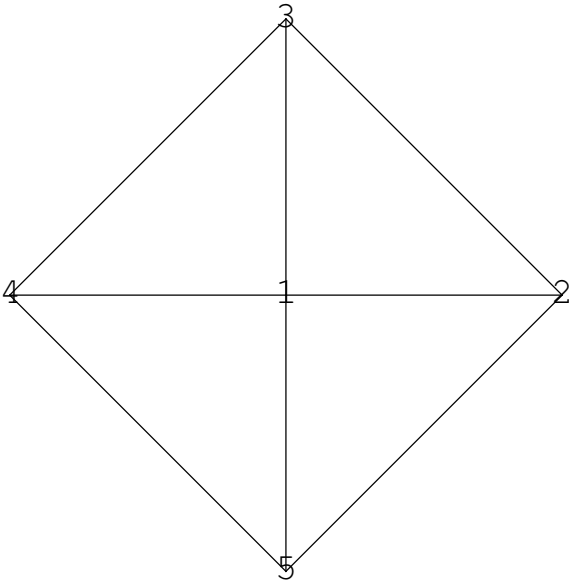

6.

cube

{4, 4, 4}

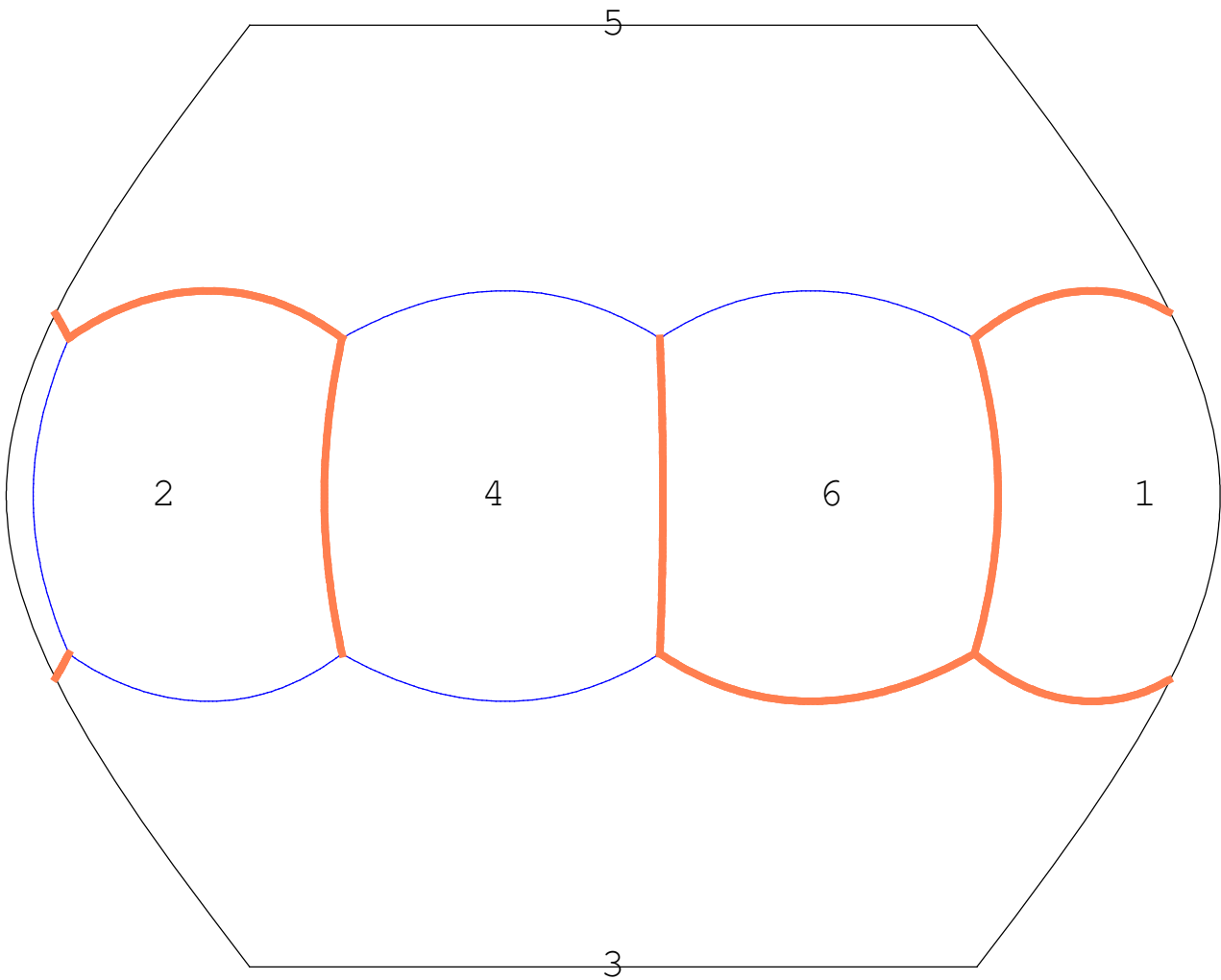
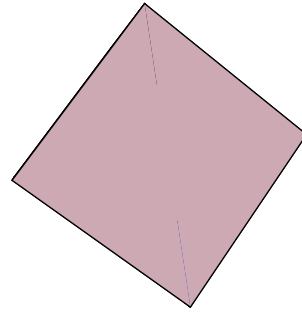
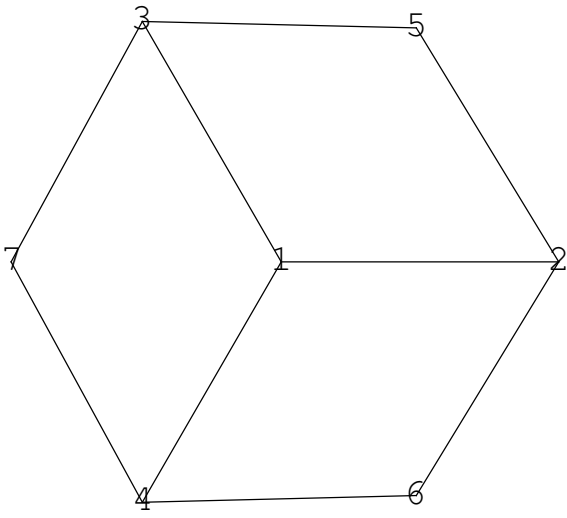

7.

cuboctahedron

{3, 4, 3, 4}

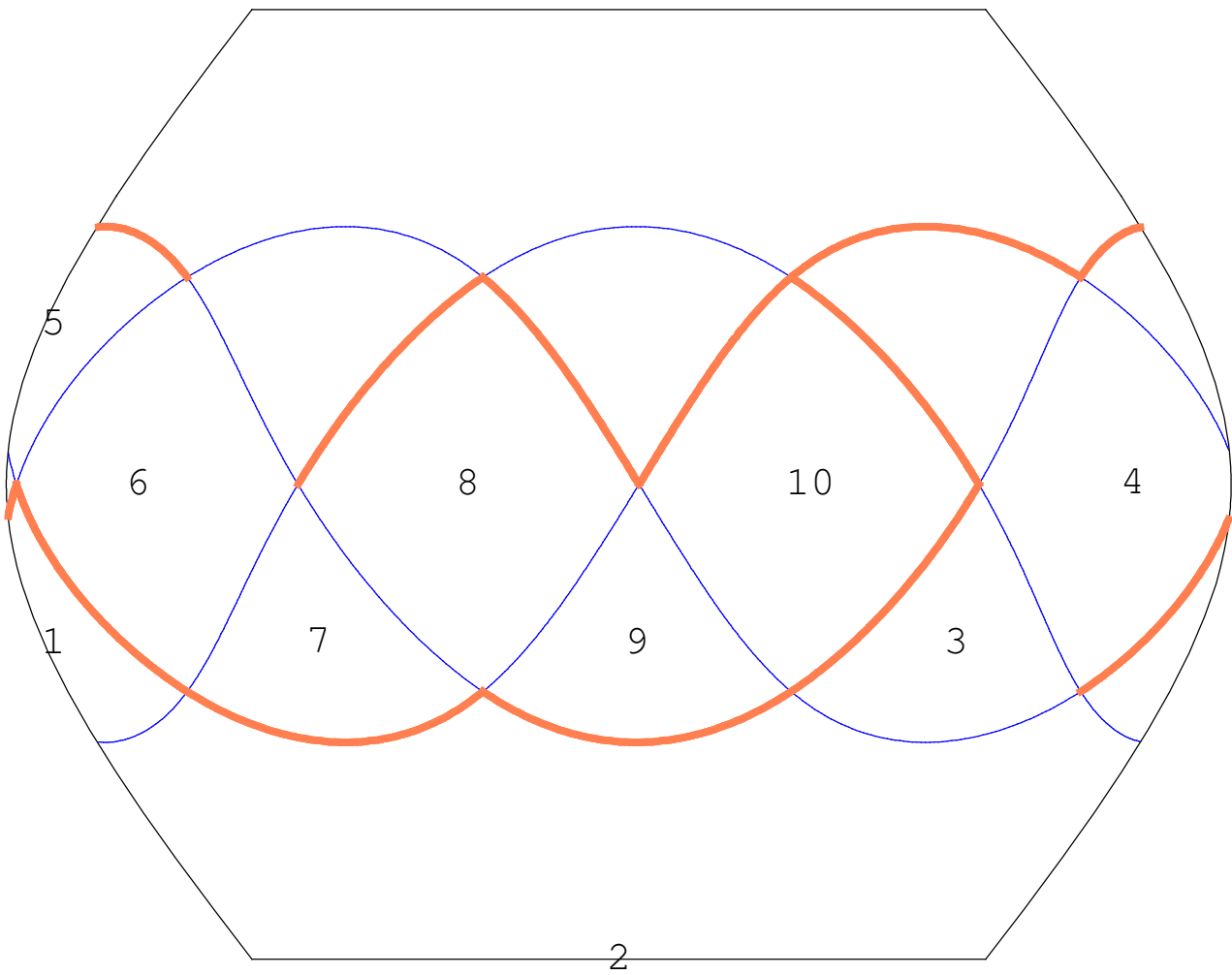
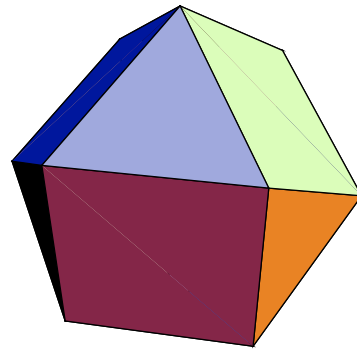
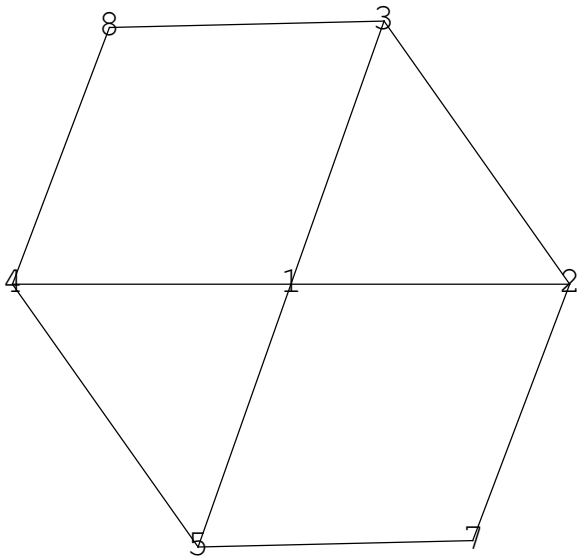

8.

truncated octahedron

{6, 6, 4}

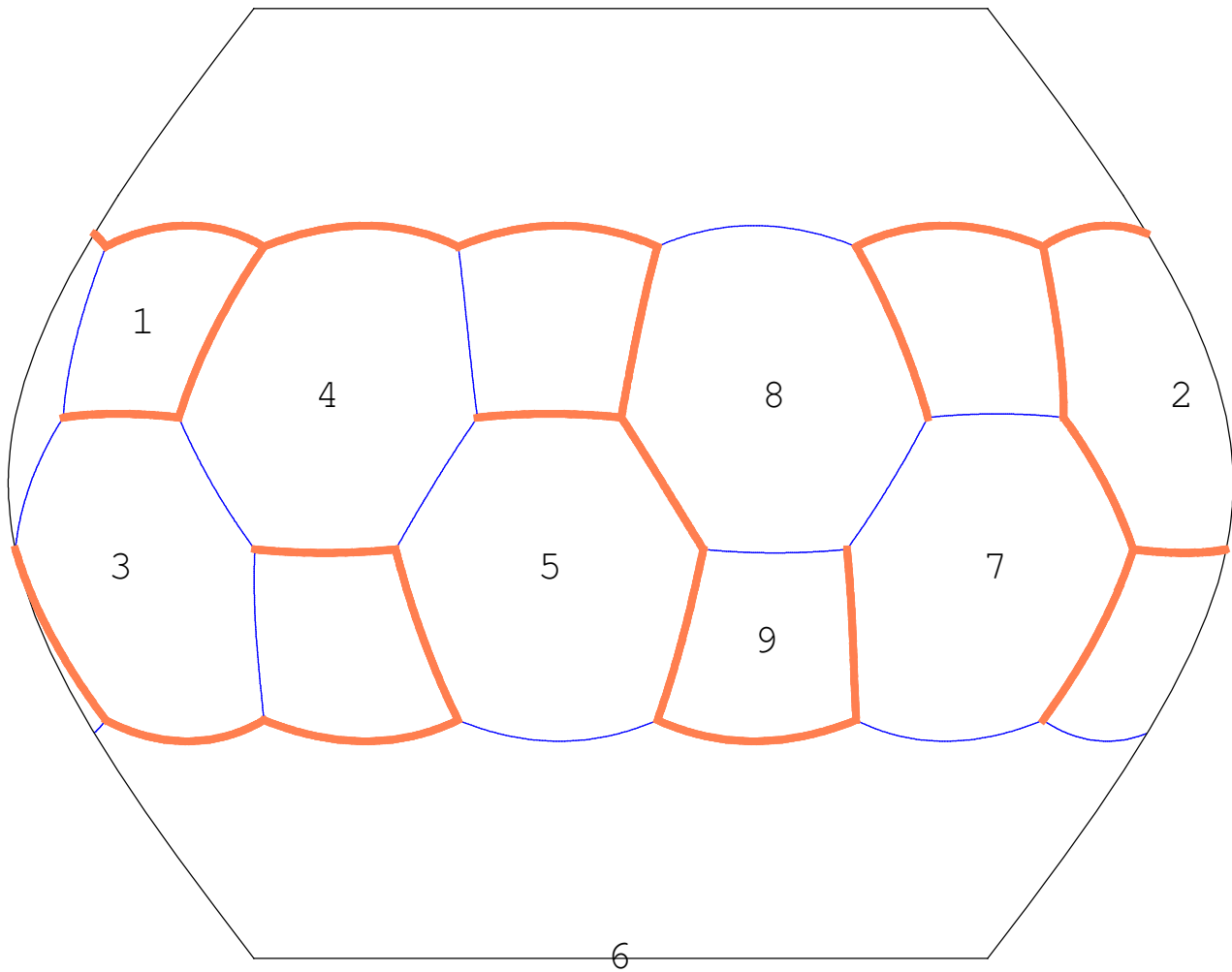
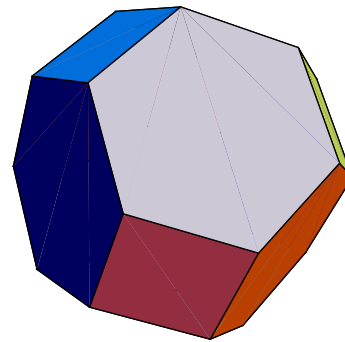
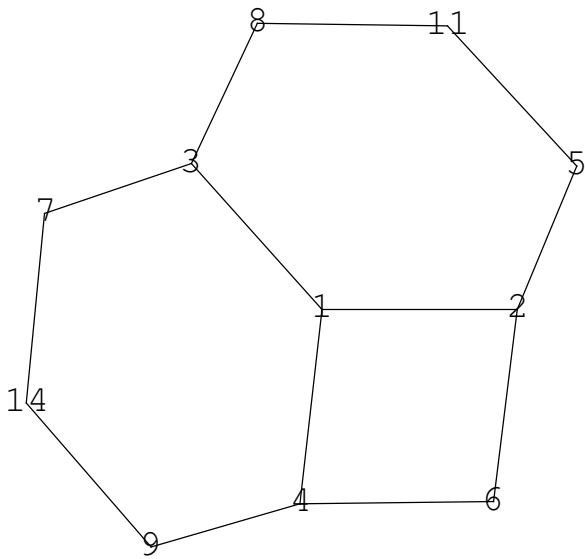

9.

truncated cube

{8, 8, 3}

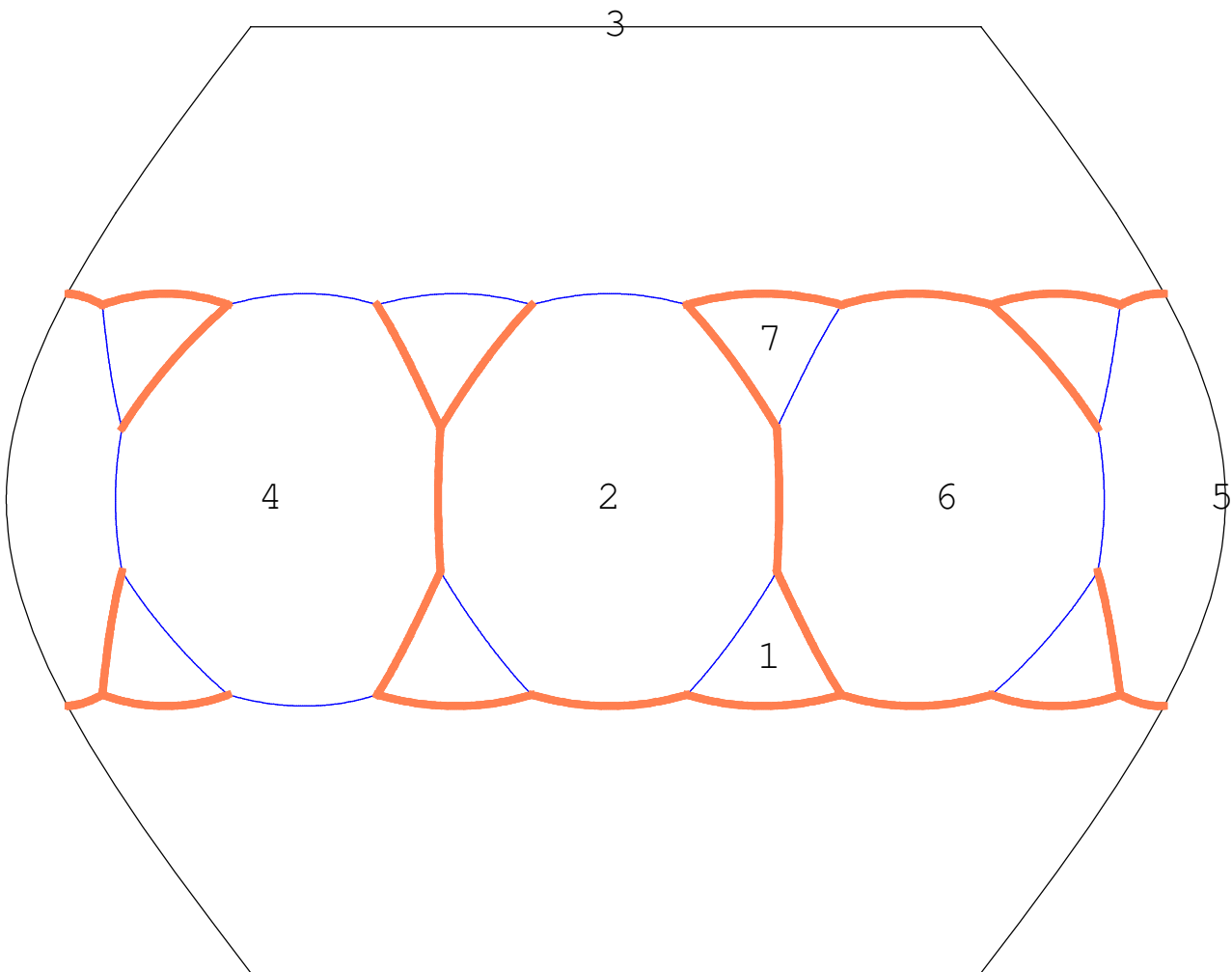
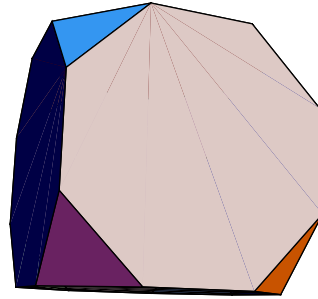
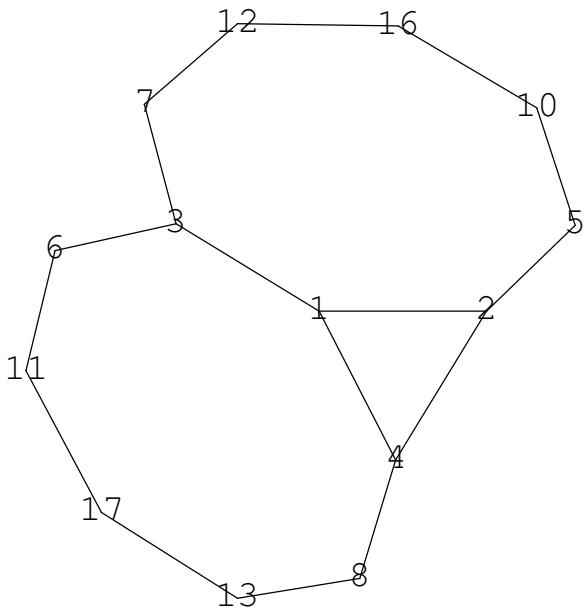

10.

rhombicuboctahedron

{4, 3, 4, 4}

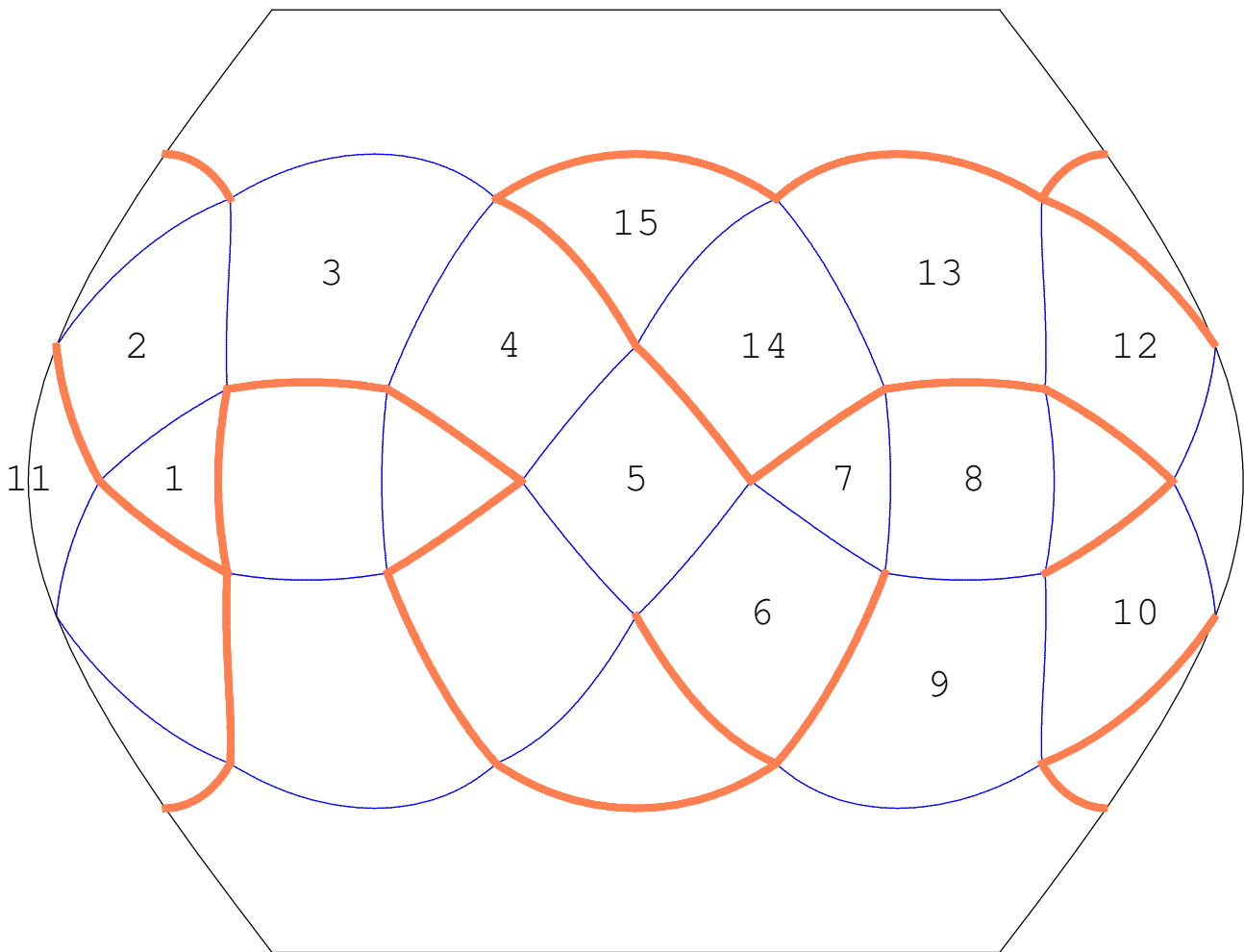
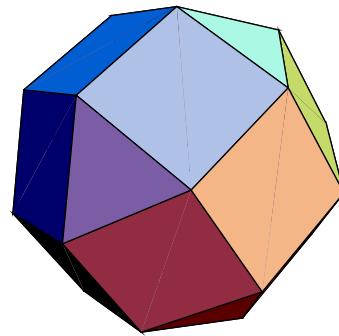
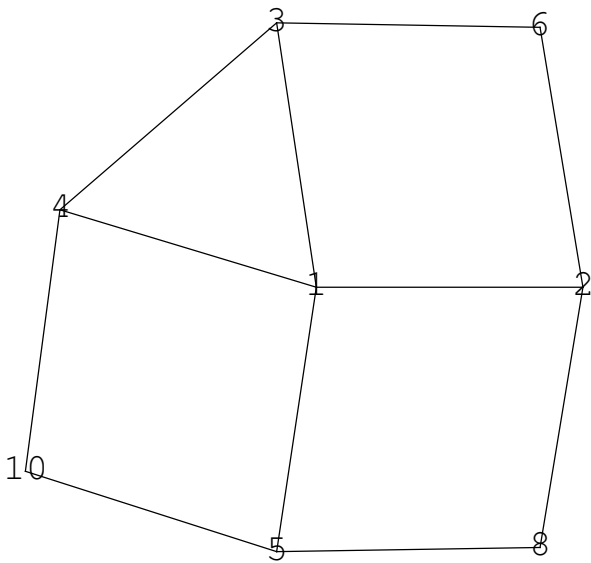

11.

truncated cuboctahedron

{4, 6, 8}

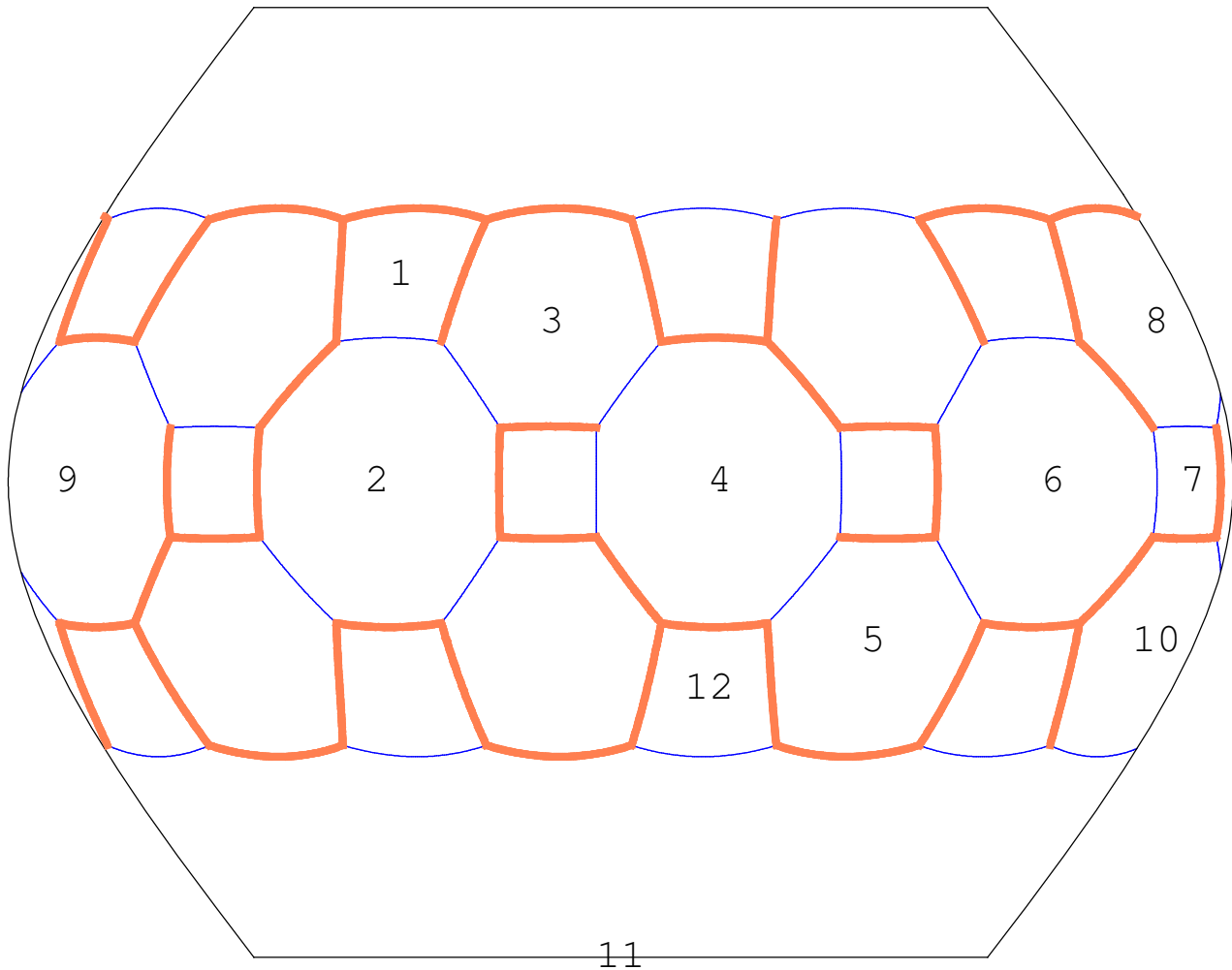
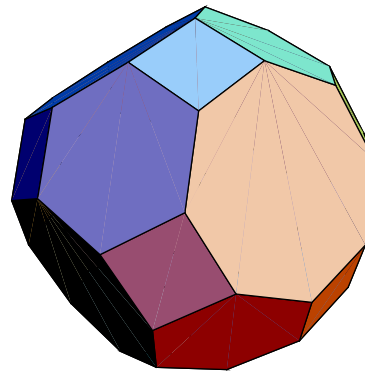
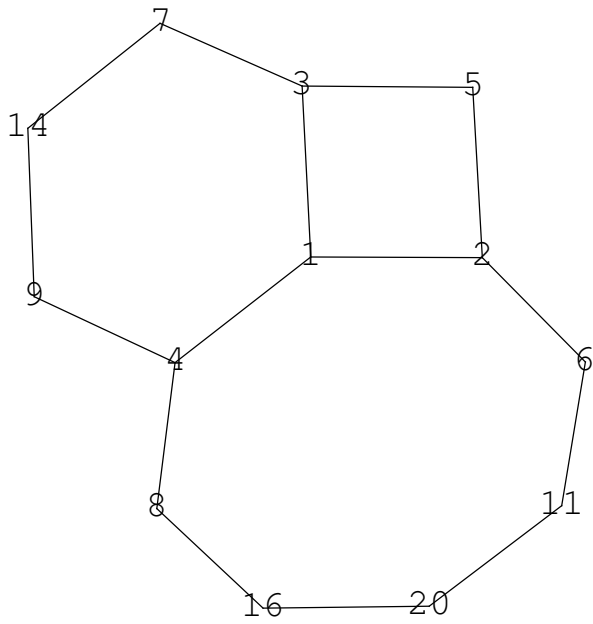

12.

snub cube

{3, 3, 3, 3, 4}

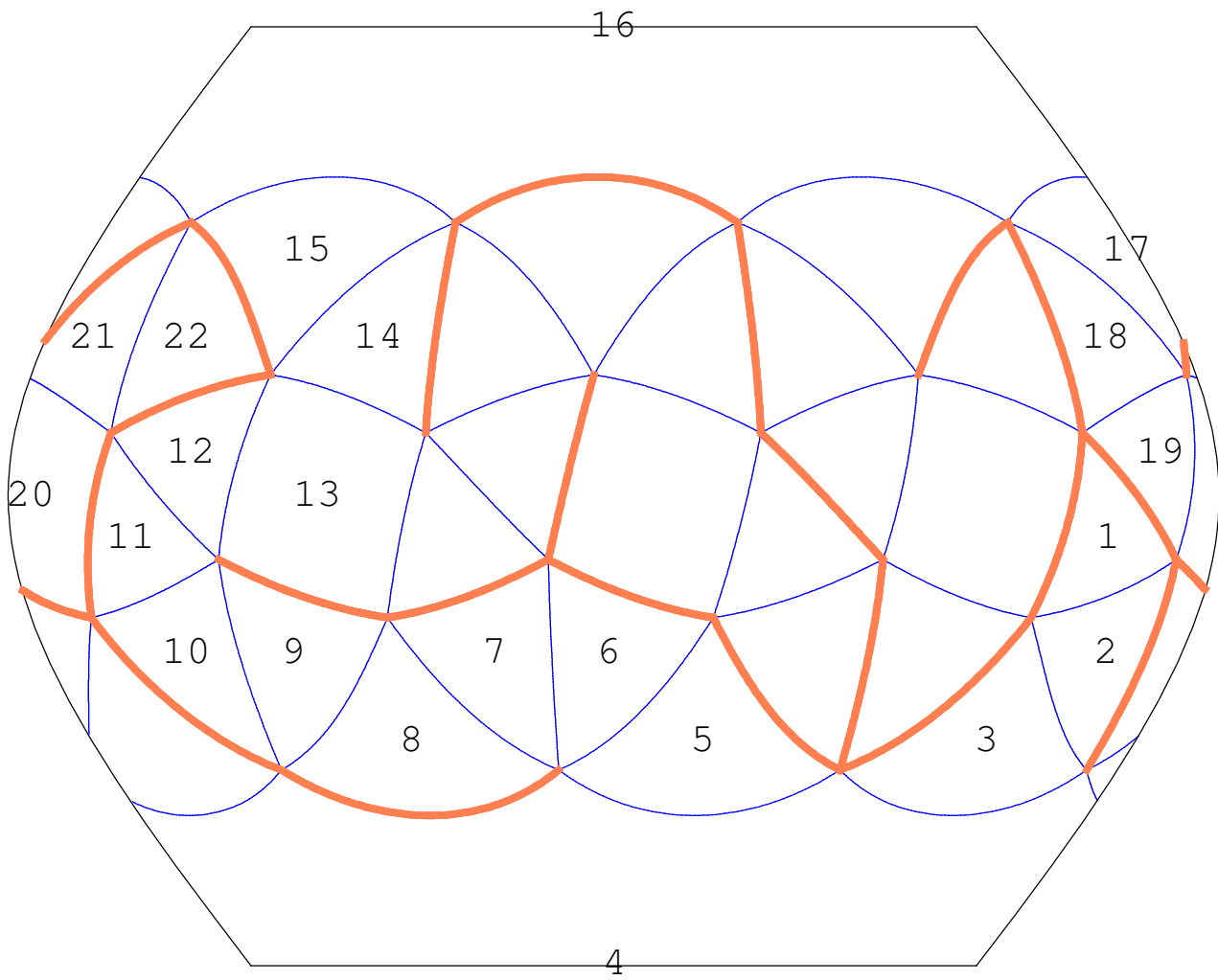
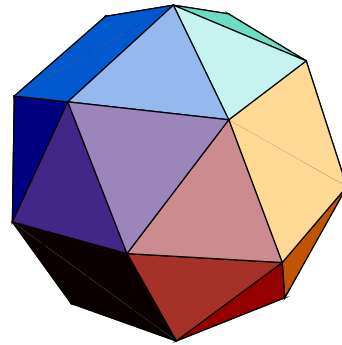
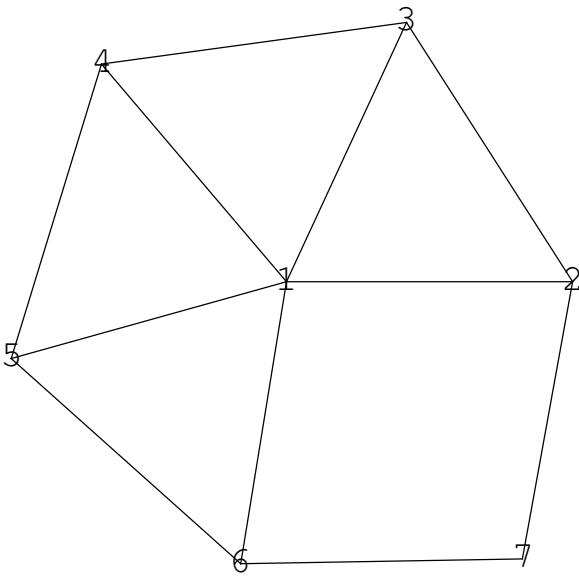

13.

small cubicuboctahedron

$$\{8, \frac{3}{2}, 8, 4\}$$

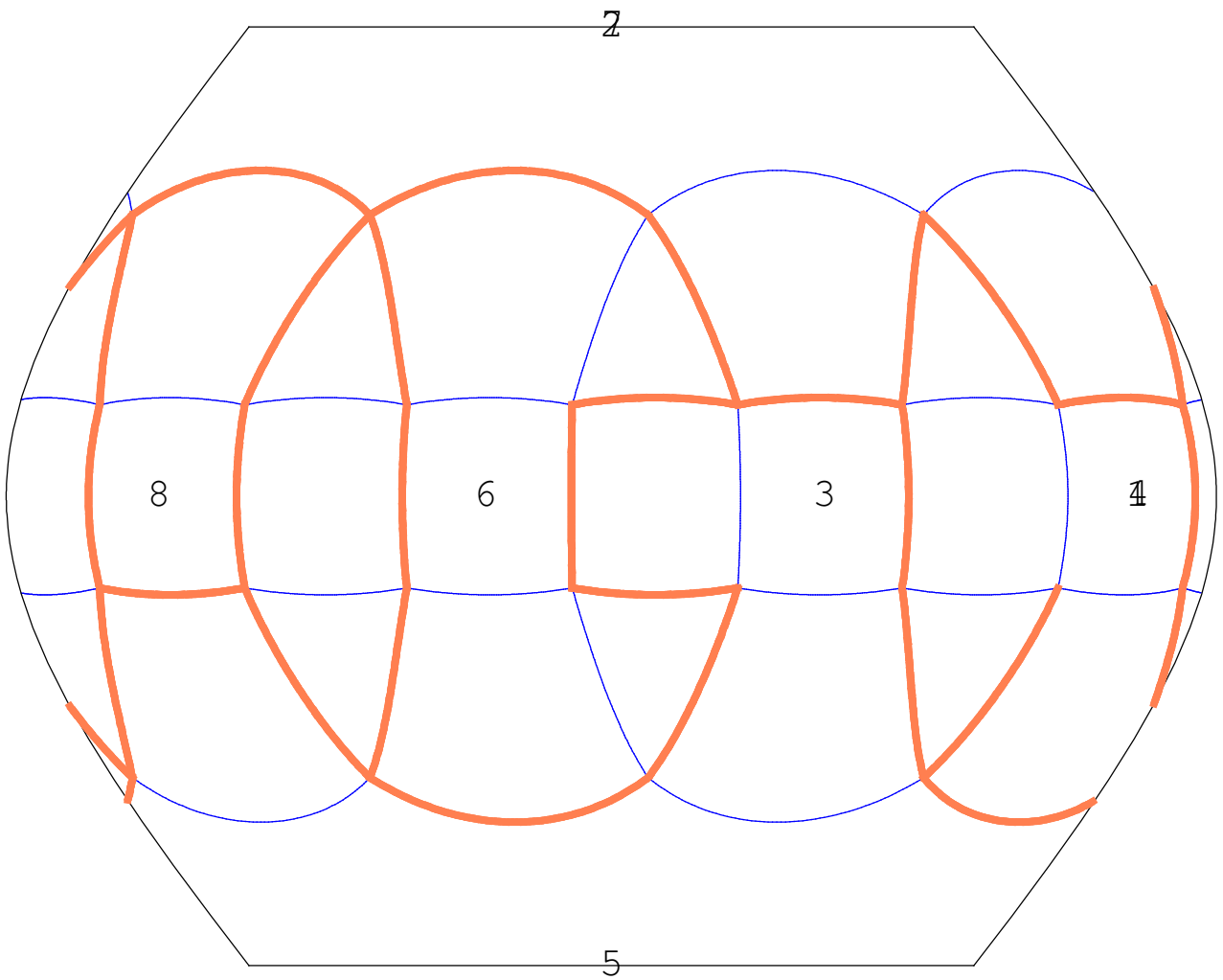
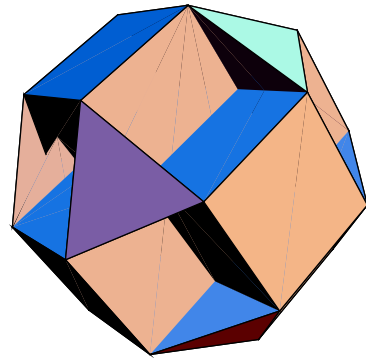
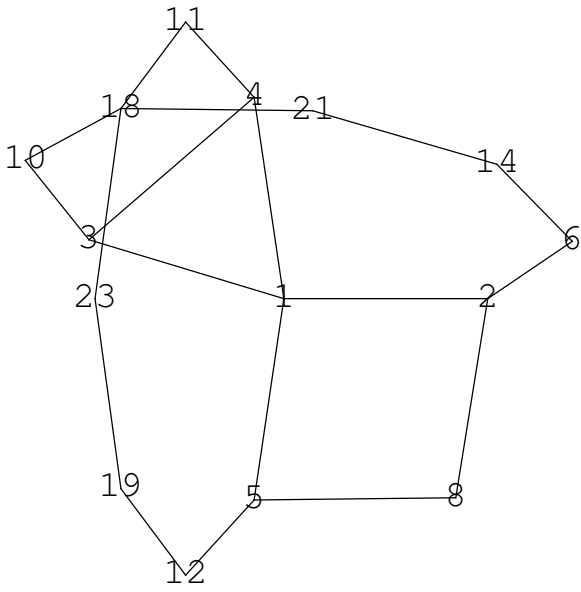

14.

great cubicuboctahedron

$$\left\{ \frac{8}{3}, 3, \frac{8}{3}, 4 \right\}$$

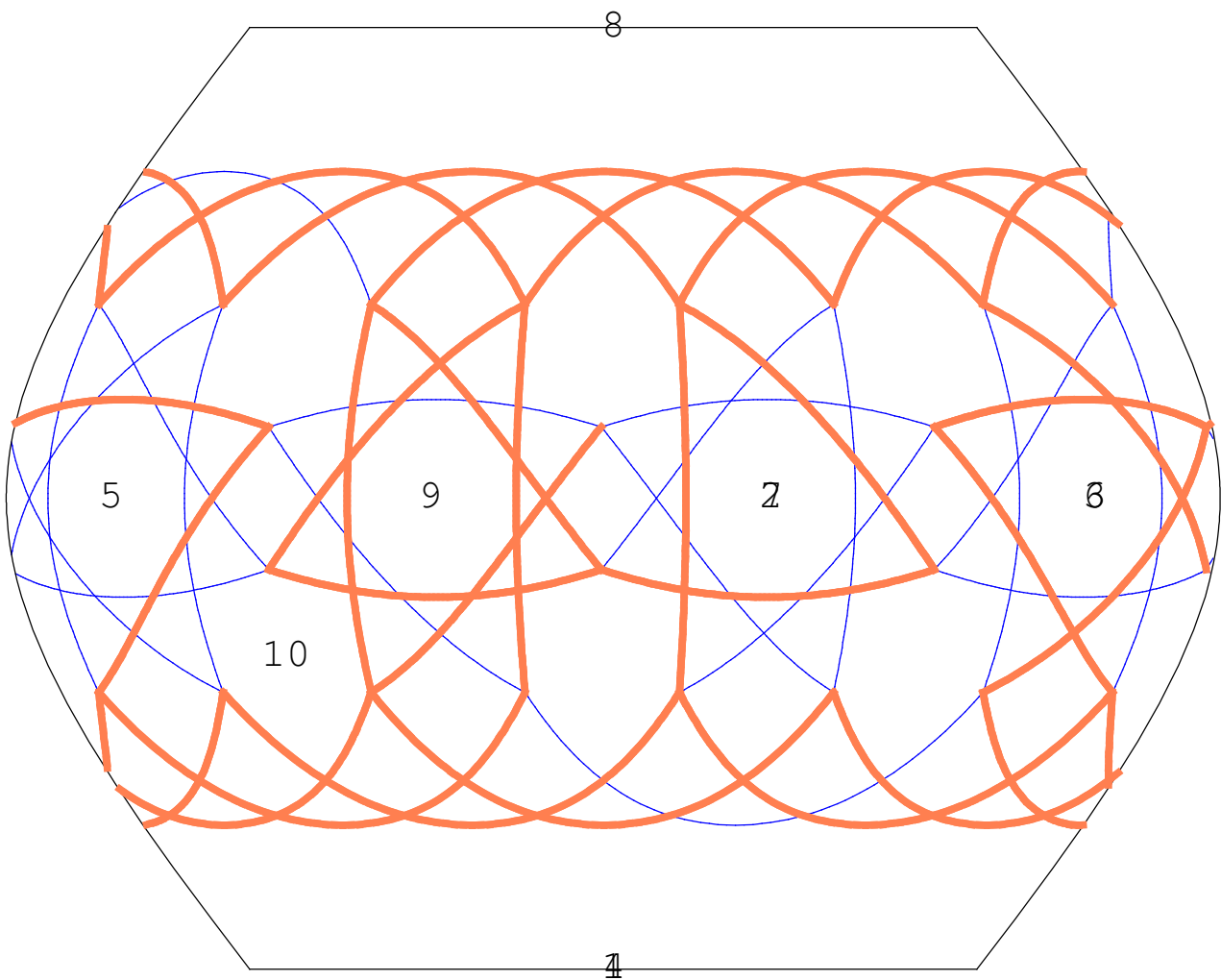
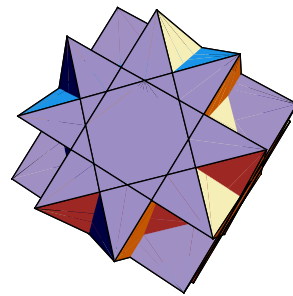
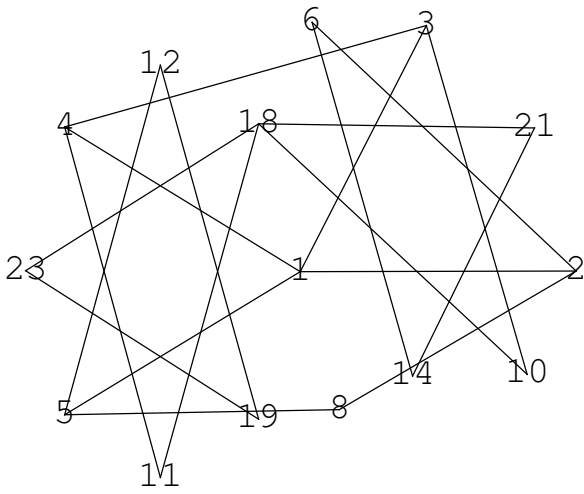

15.

cubohemioctahedron

$$\left\{6, \frac{4}{3}, 6, 4\right\}$$

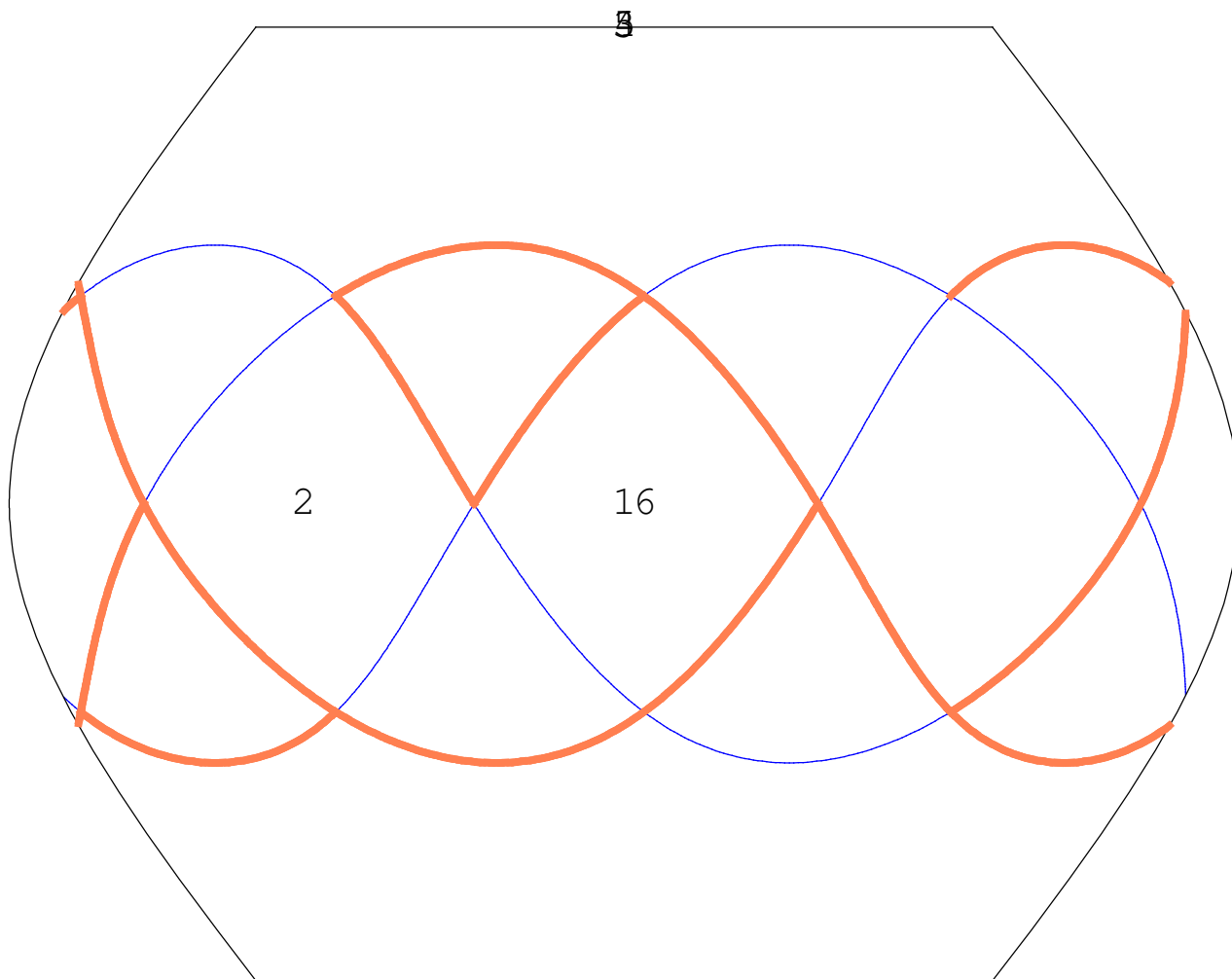
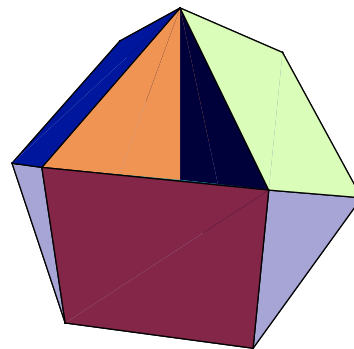
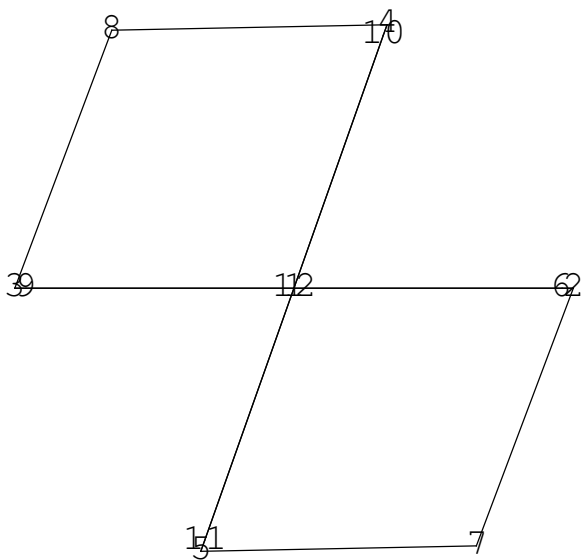

16.

cubitruncated cuboctahedron

$$\left\{ \frac{8}{3}, 6, 8 \right\}$$

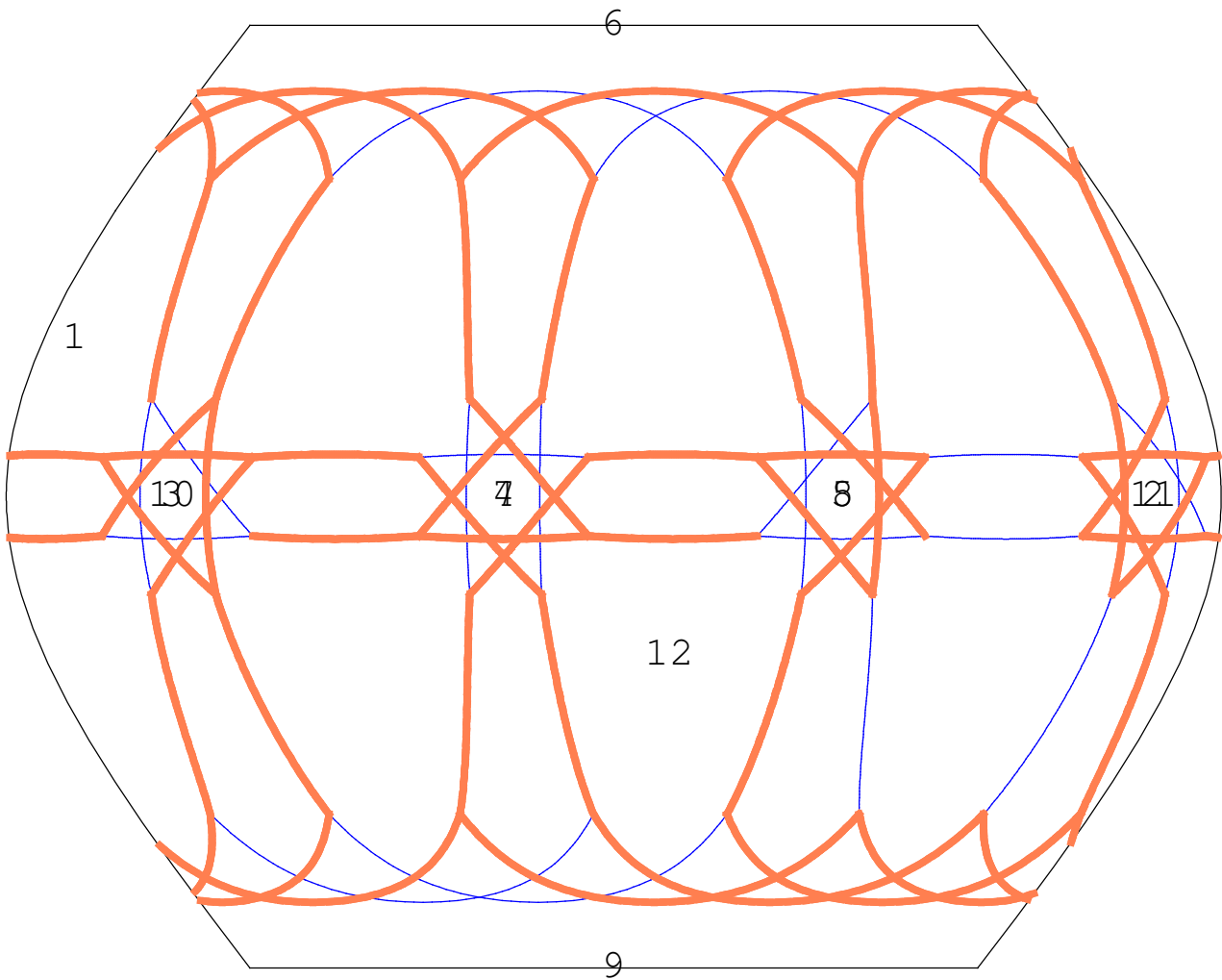
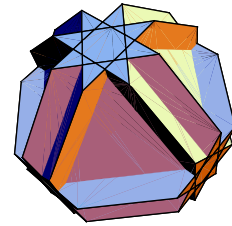
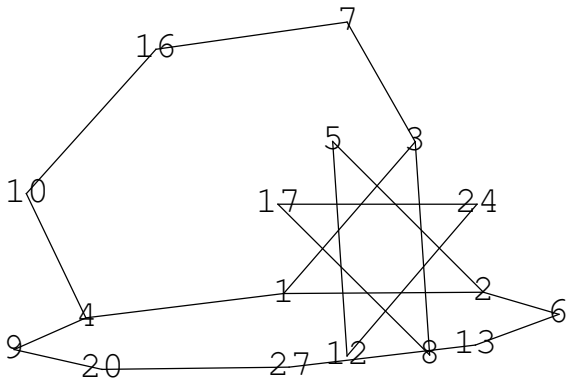

17.

great rhombicuboctahedron

$$\{4, \frac{3}{2}, 4, 4\}$$

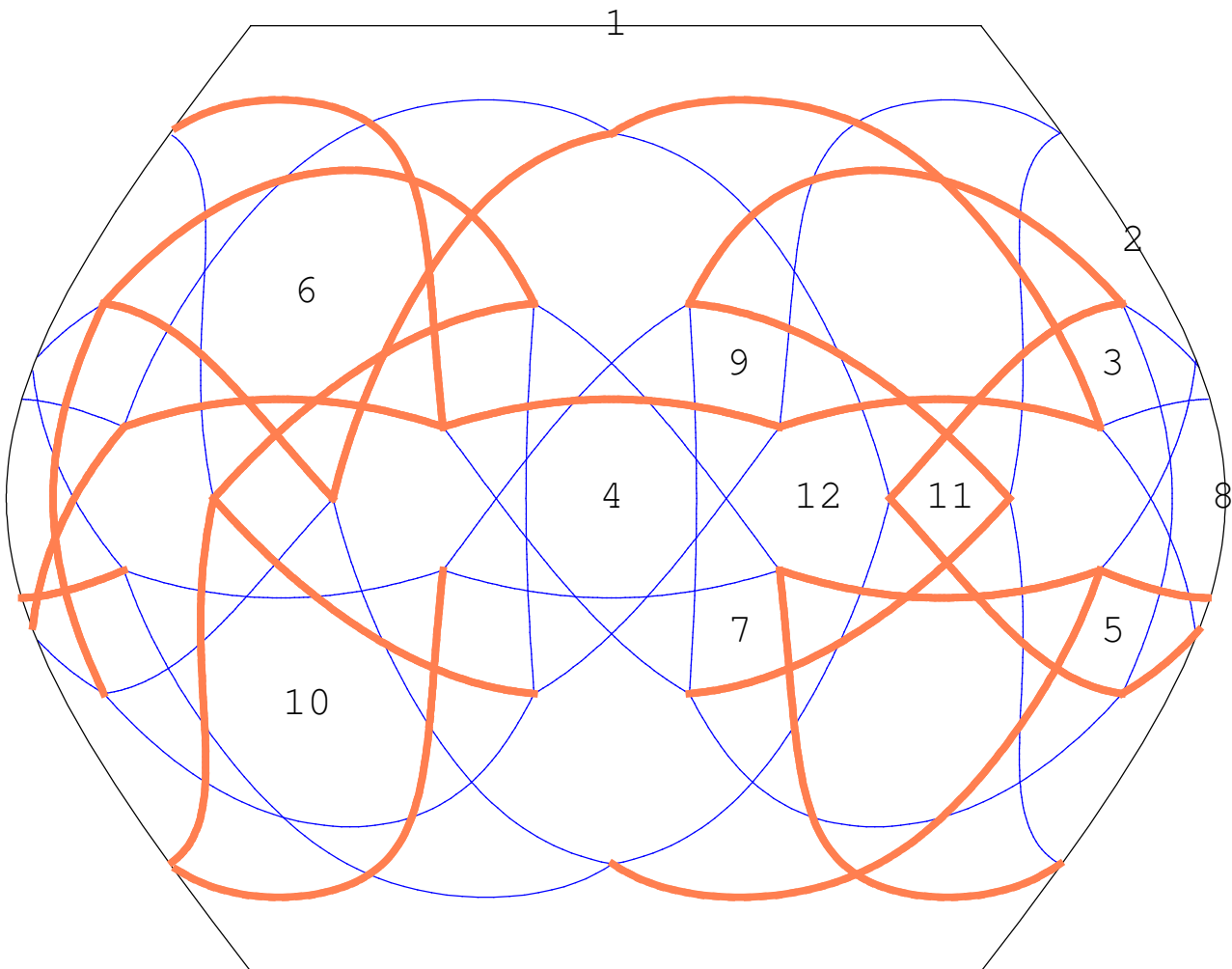
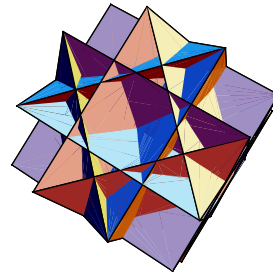
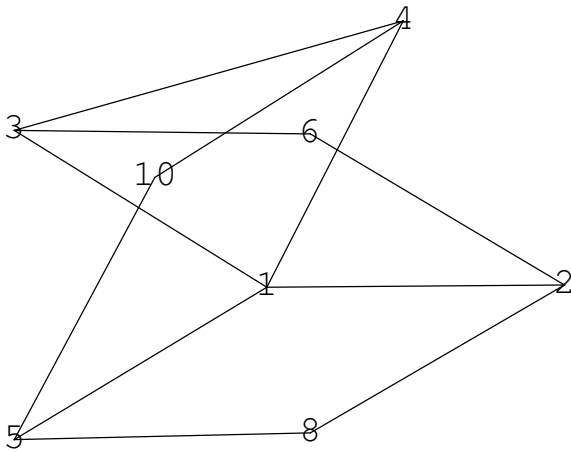

18.

small rhombihexahedron

$$\{8, 4, \frac{8}{7}, \frac{4}{3}\}$$

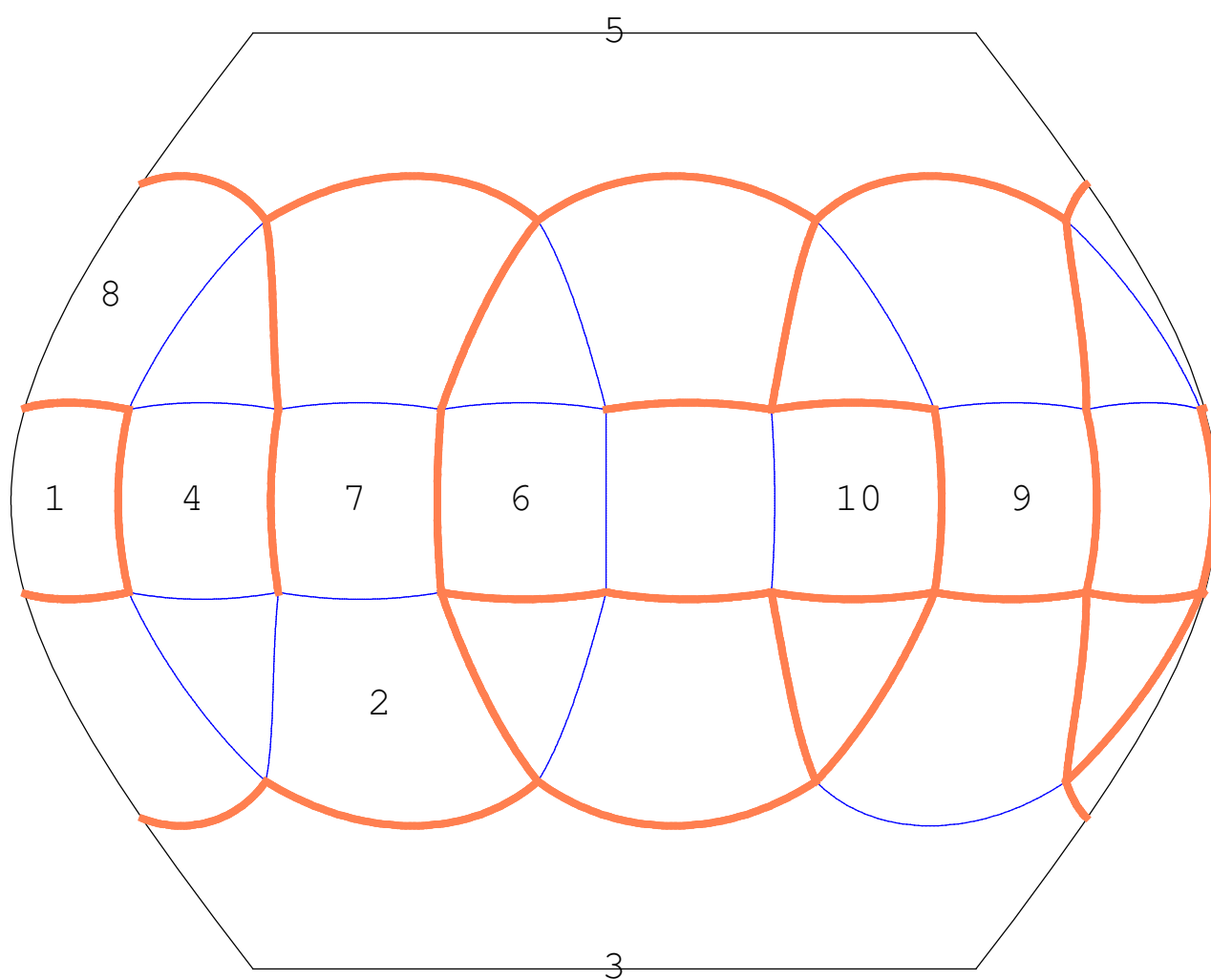
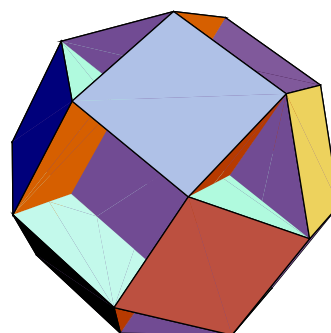
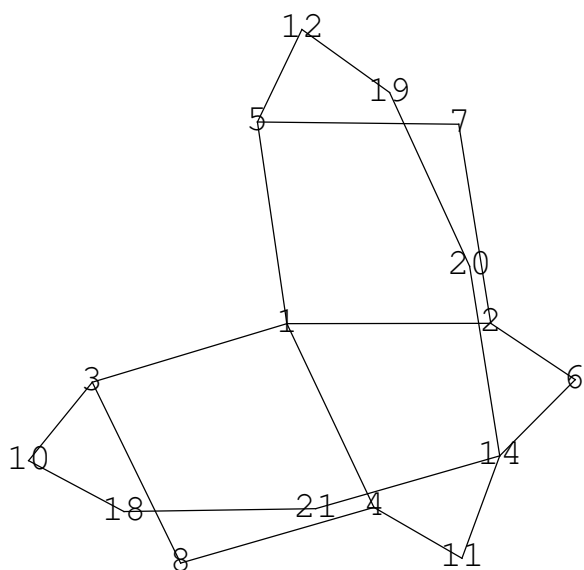

19.

stellated truncated hexahedron

$$\left\{ \frac{8}{3}, \frac{8}{3}, 3 \right\}$$

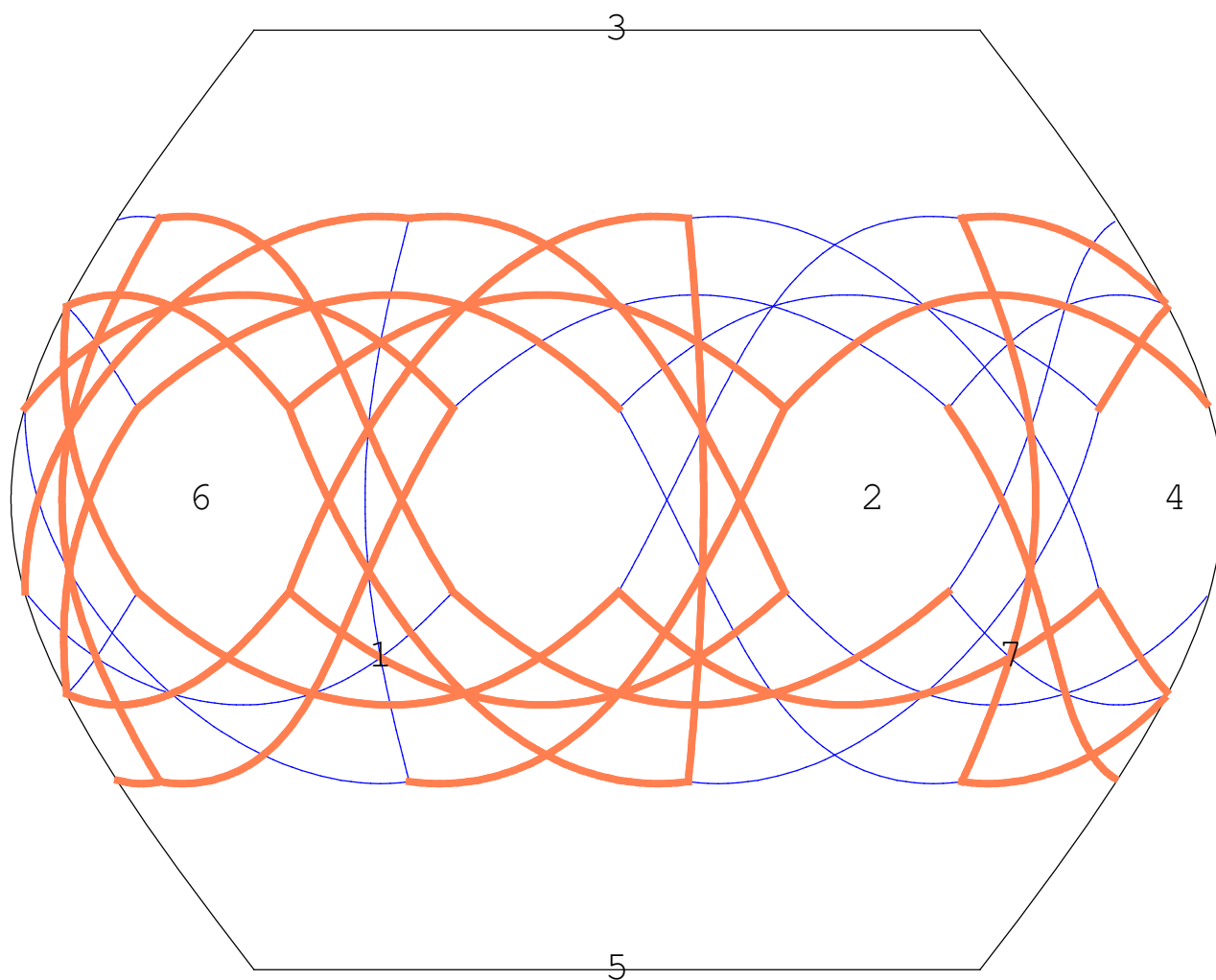
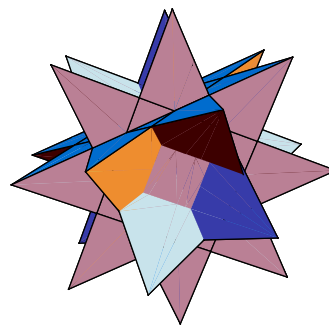
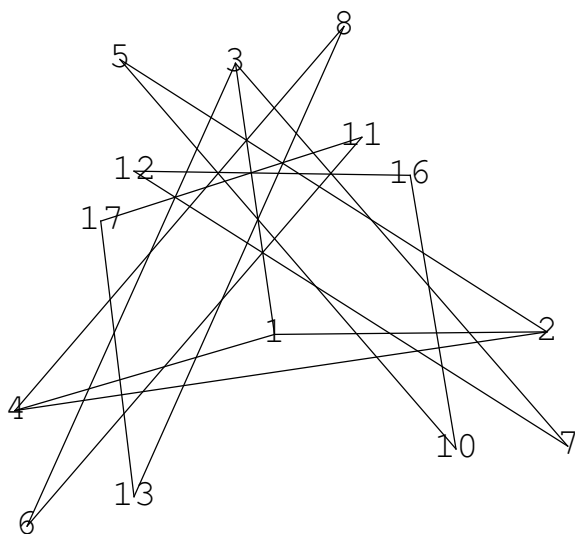

20.

great truncated cuboctahedron

$$\left\{ \frac{8}{3}, 4, 6 \right\}$$

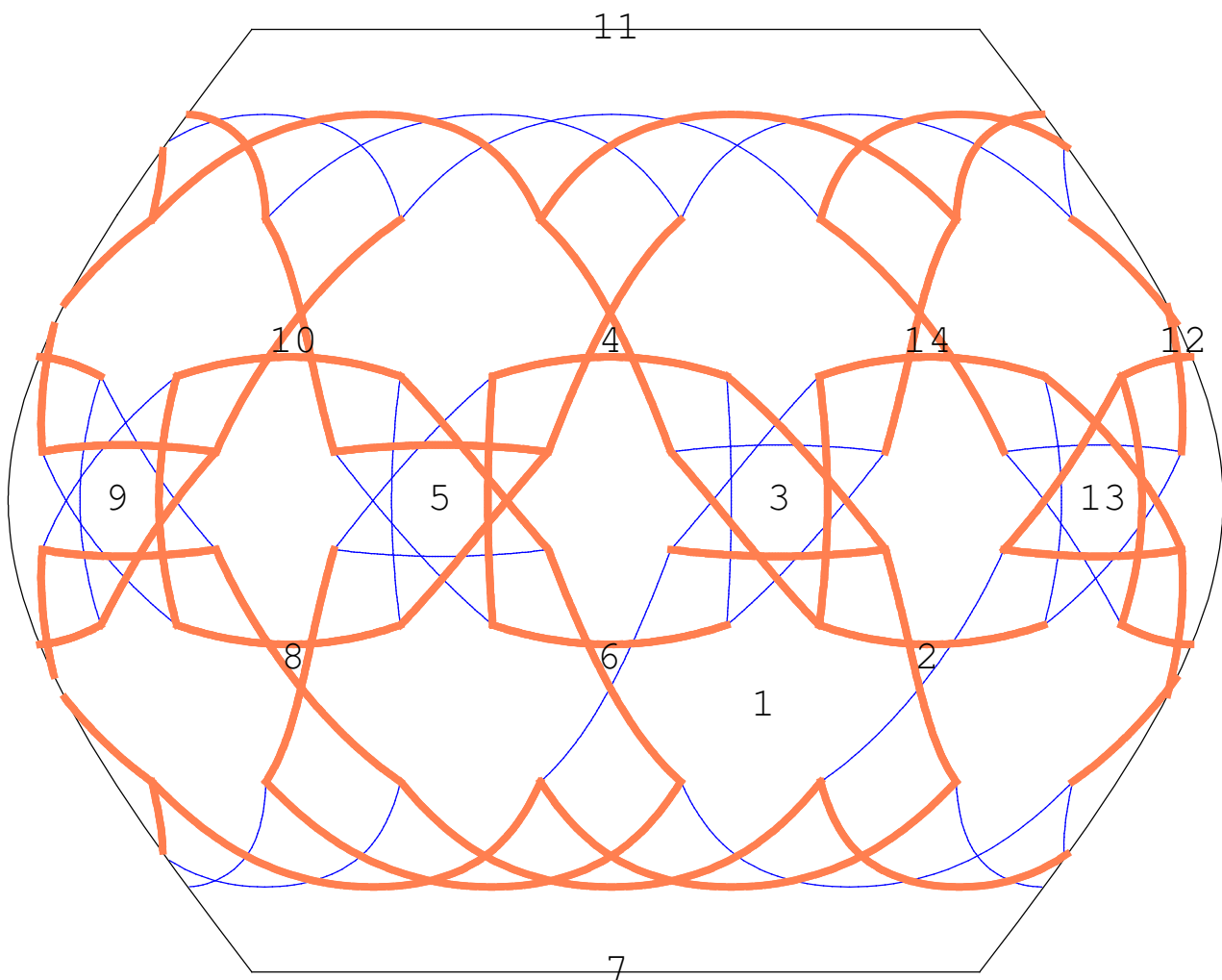
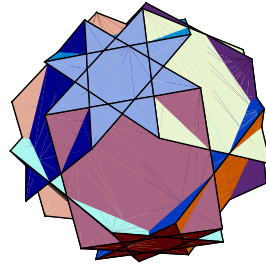
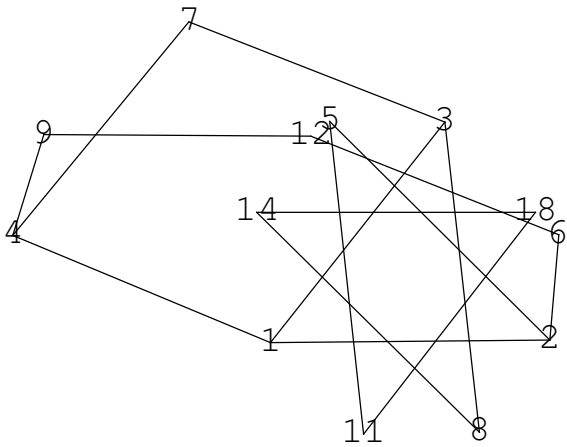

21.

great rhombihexahedron

$$\left\{4, \frac{8}{3}, \frac{4}{3}, \frac{8}{5}\right\}$$

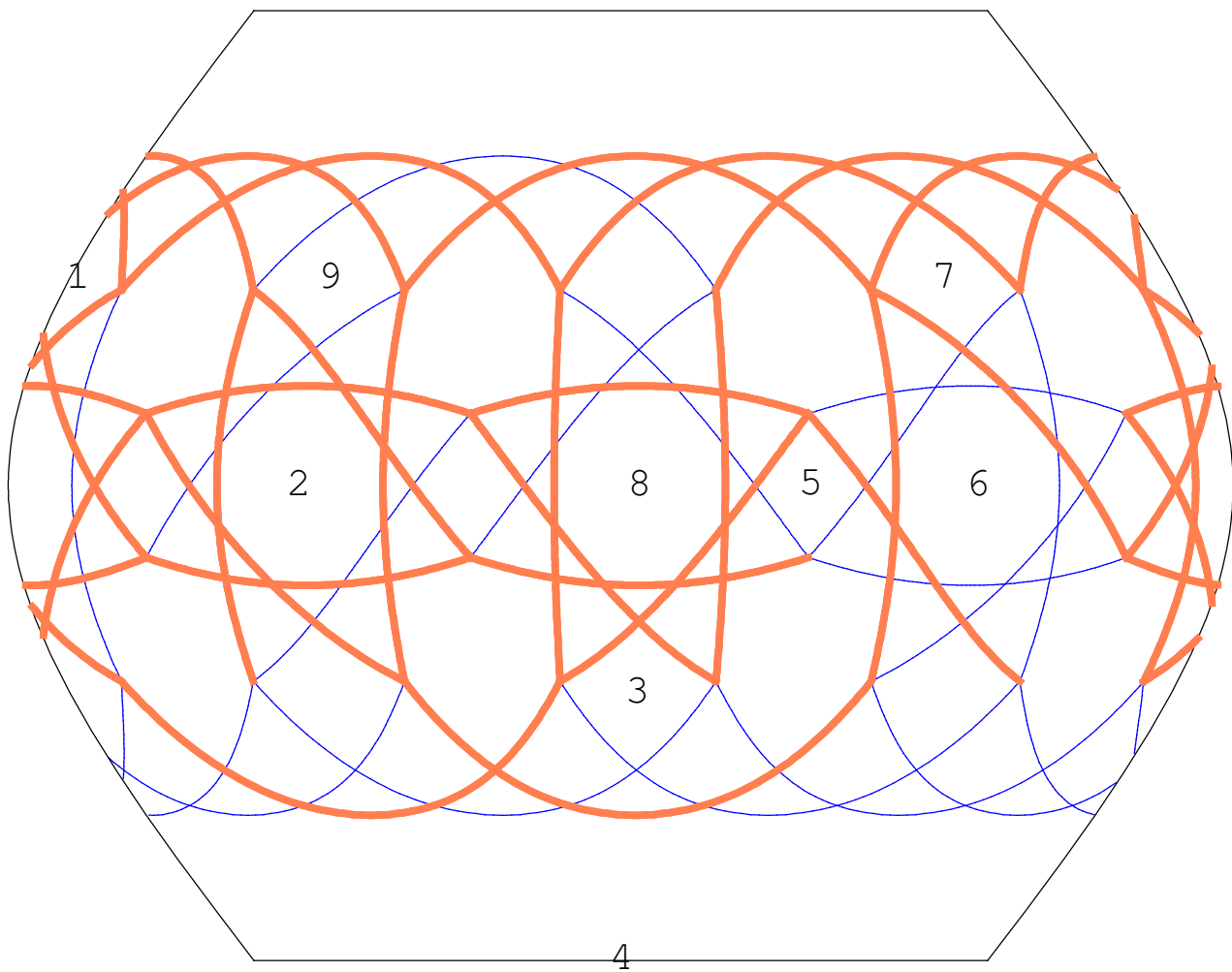
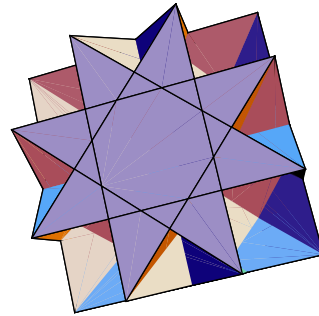
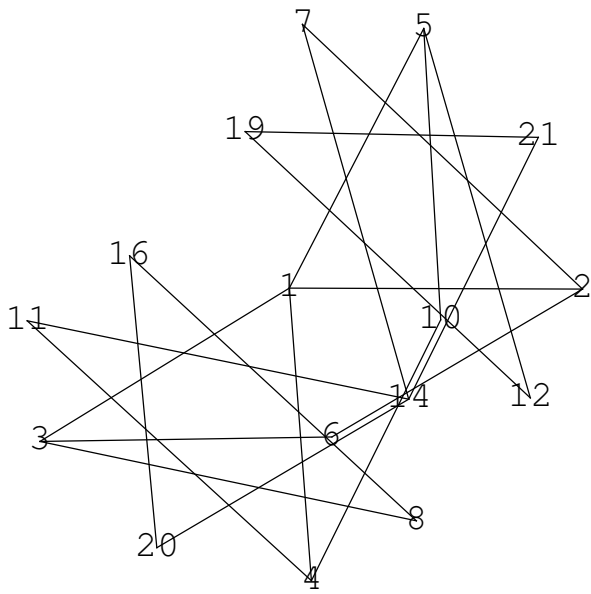

22.

icosahedron

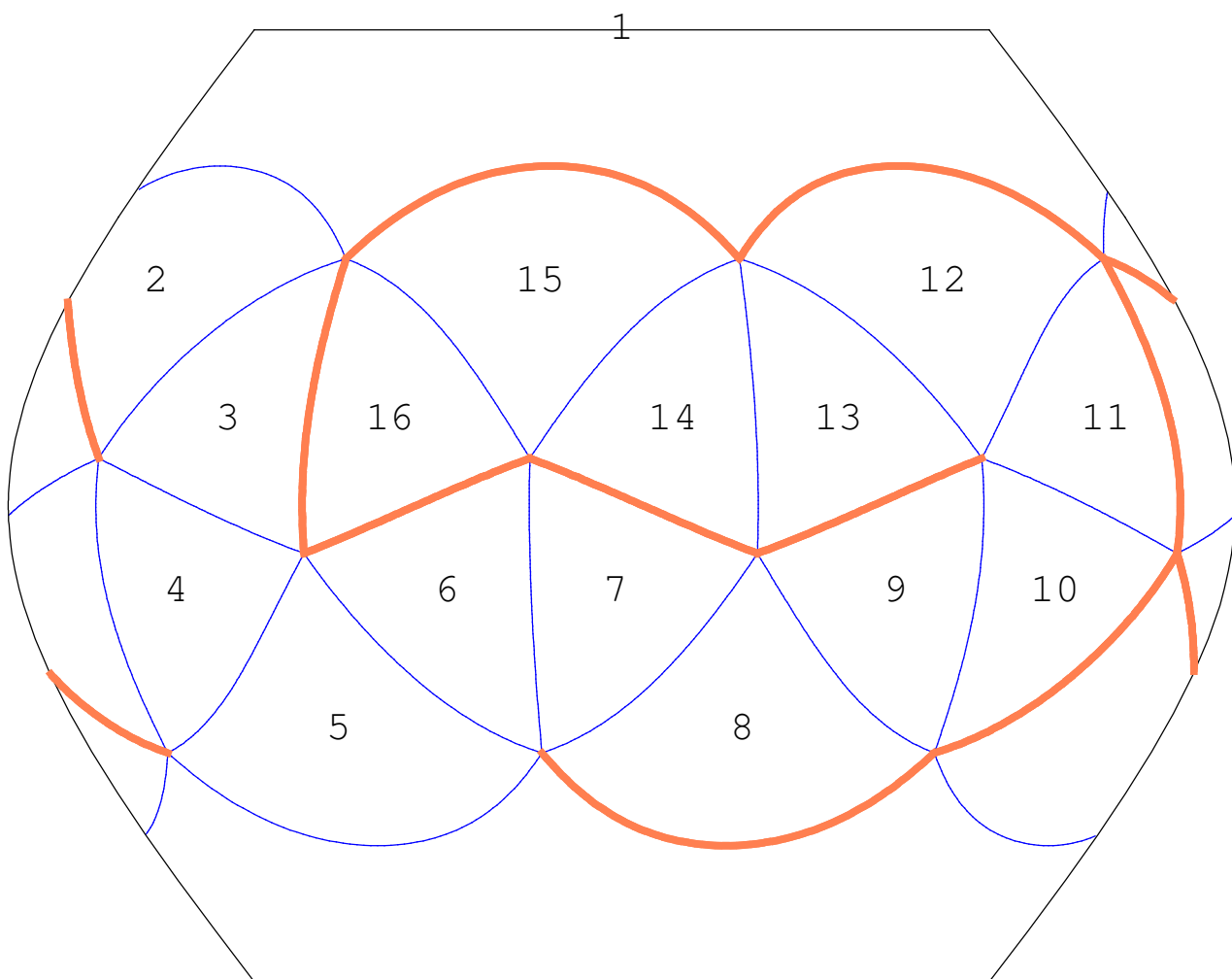
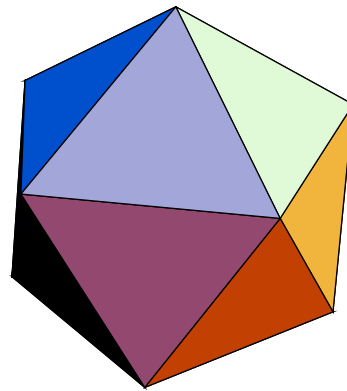
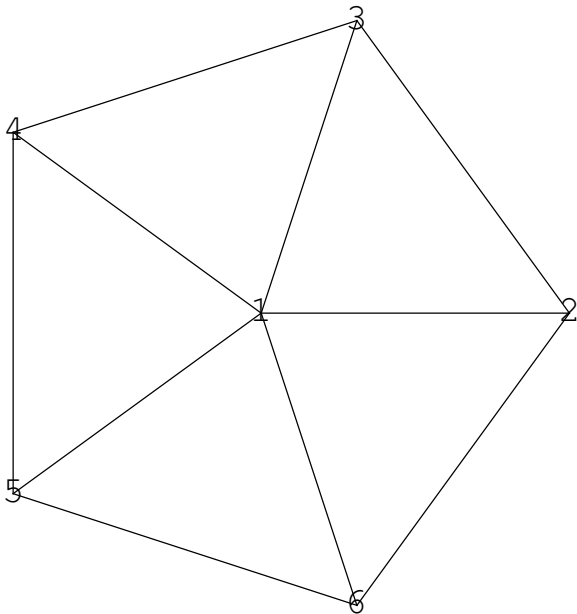
 $\{3, 3, 3, 3, 3\}$ 

23.

dodecahedron

{5, 5, 5}

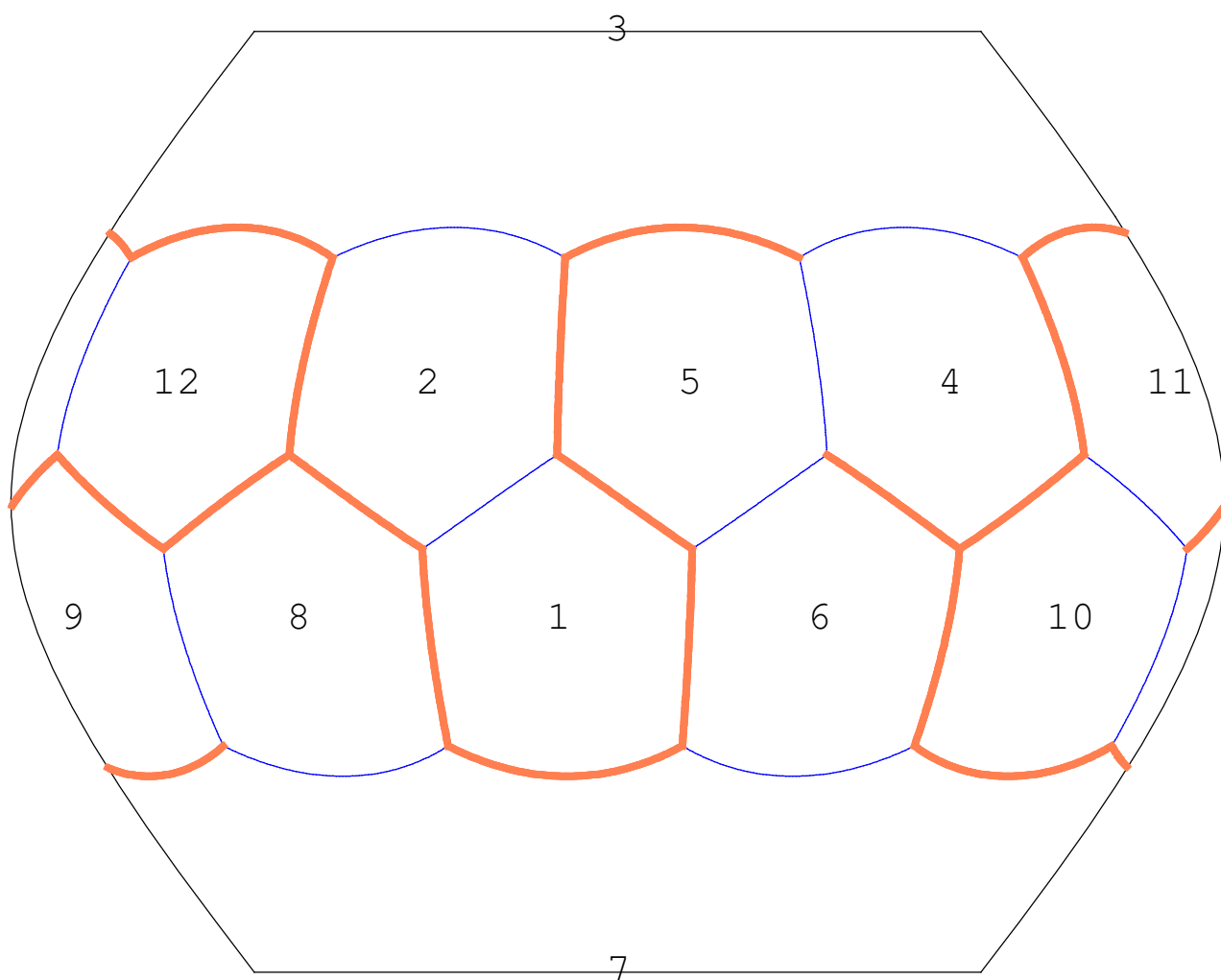
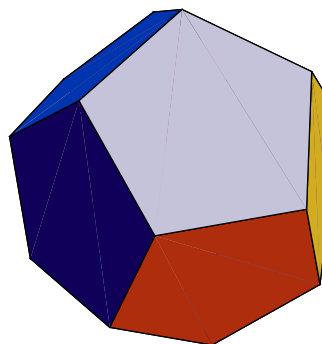
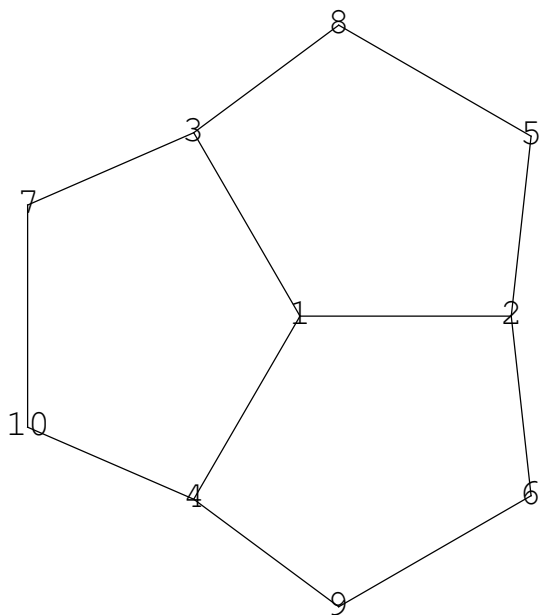

24.

icosidodecahedron

{3, 5, 3, 5}

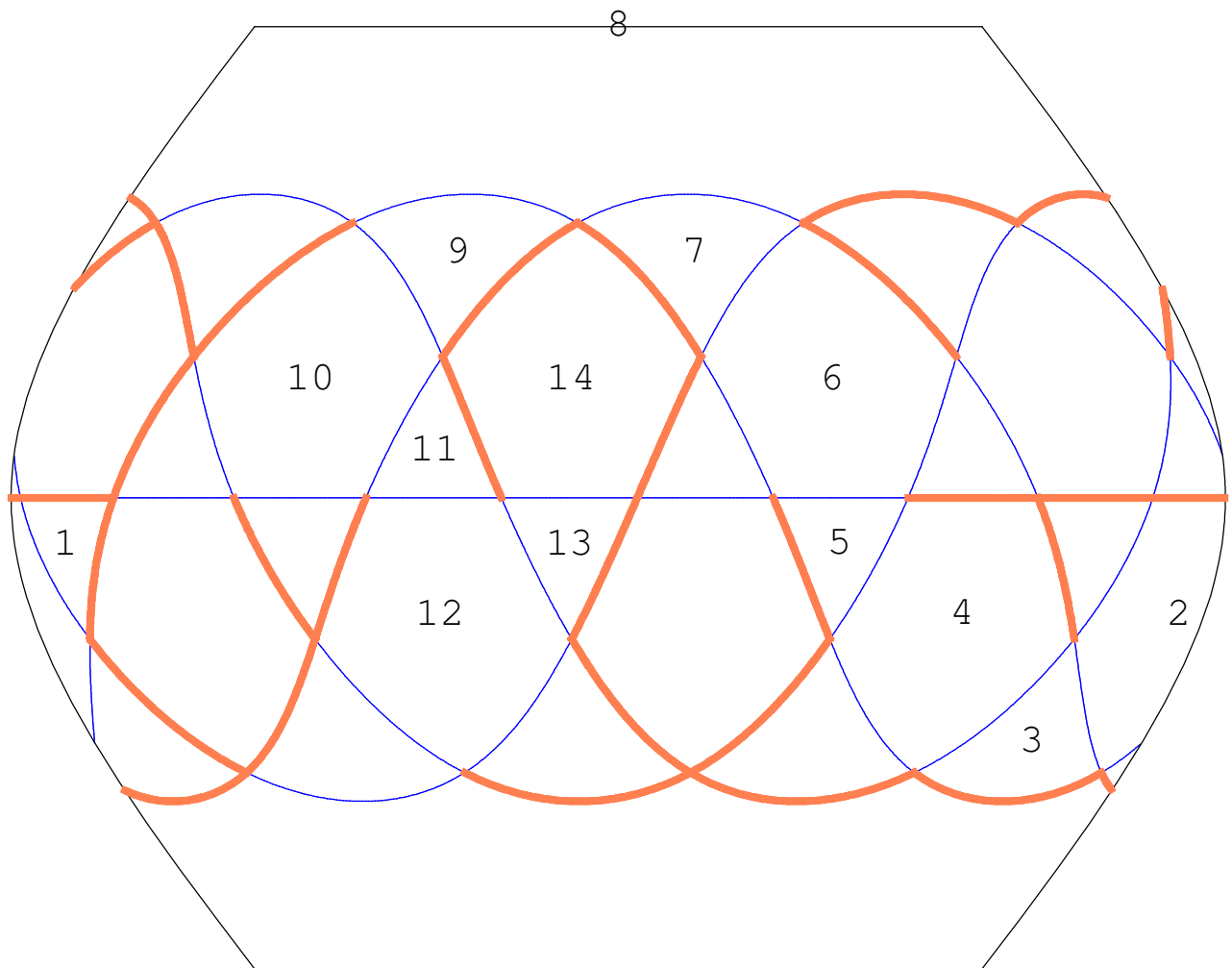
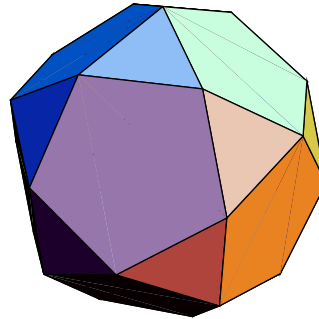
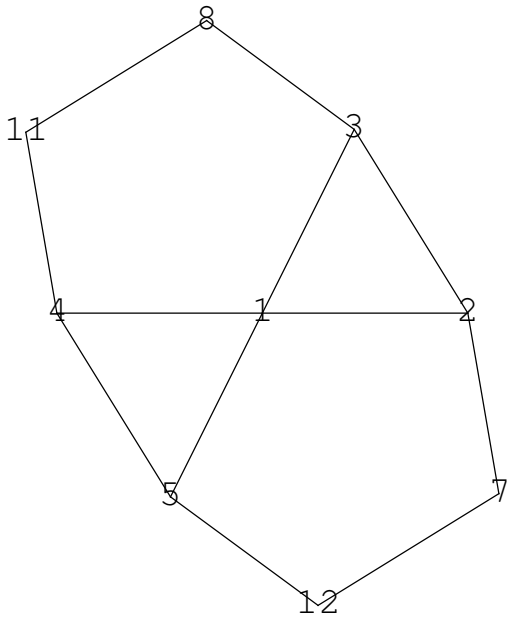

25.

truncated icosahedron

{6, 6, 5}

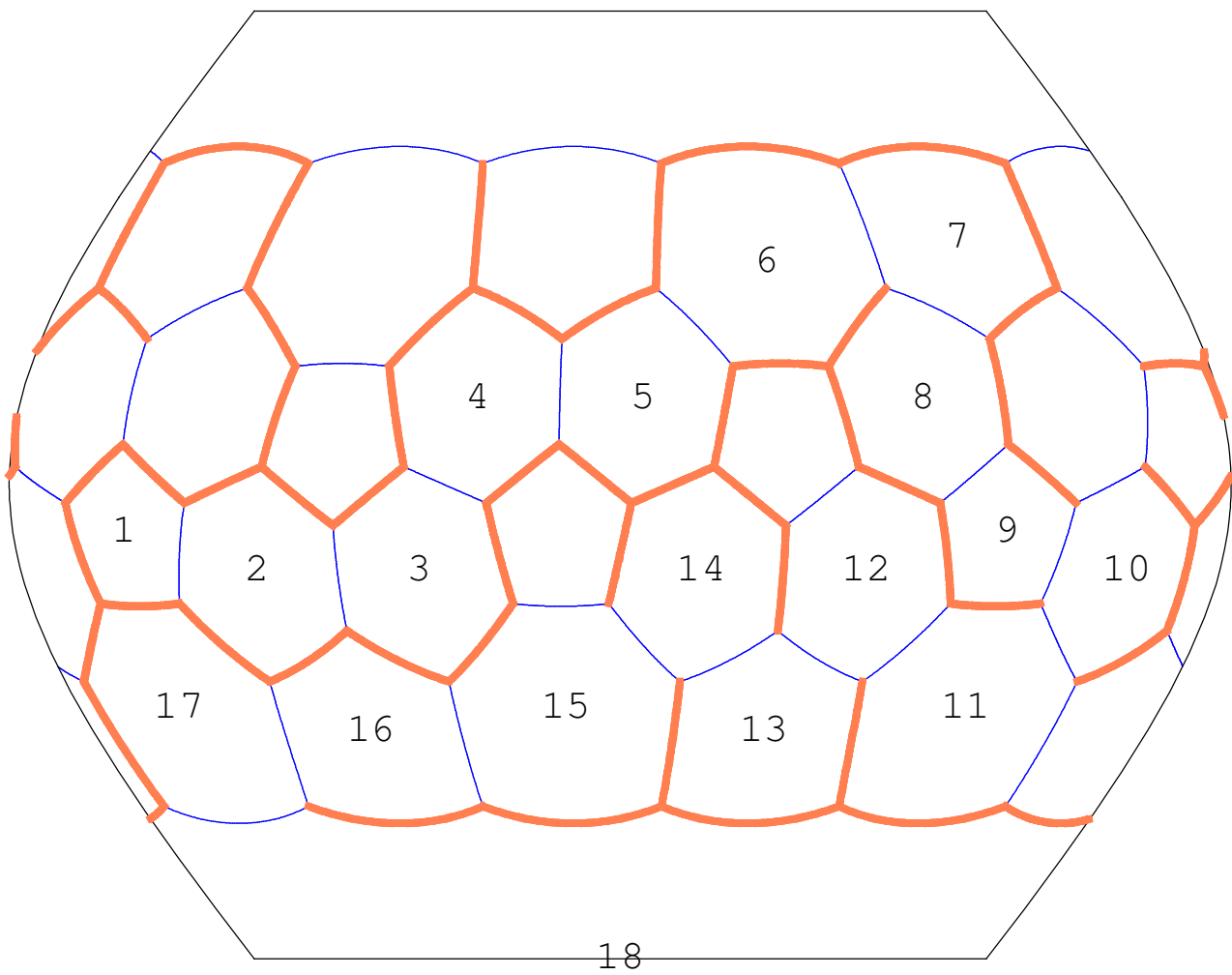
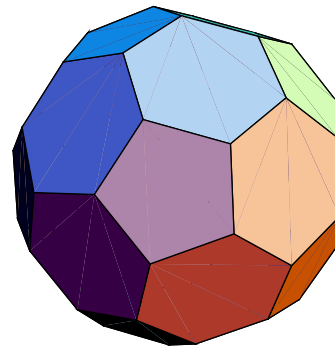
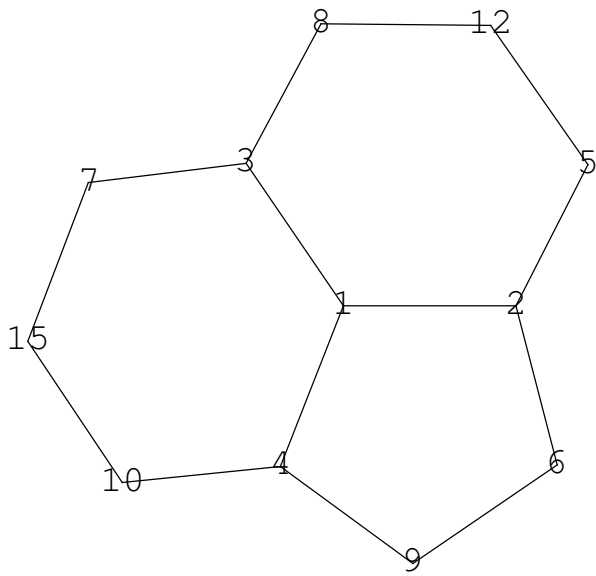

26.

truncated dodecahedron

{10, 10, 3}

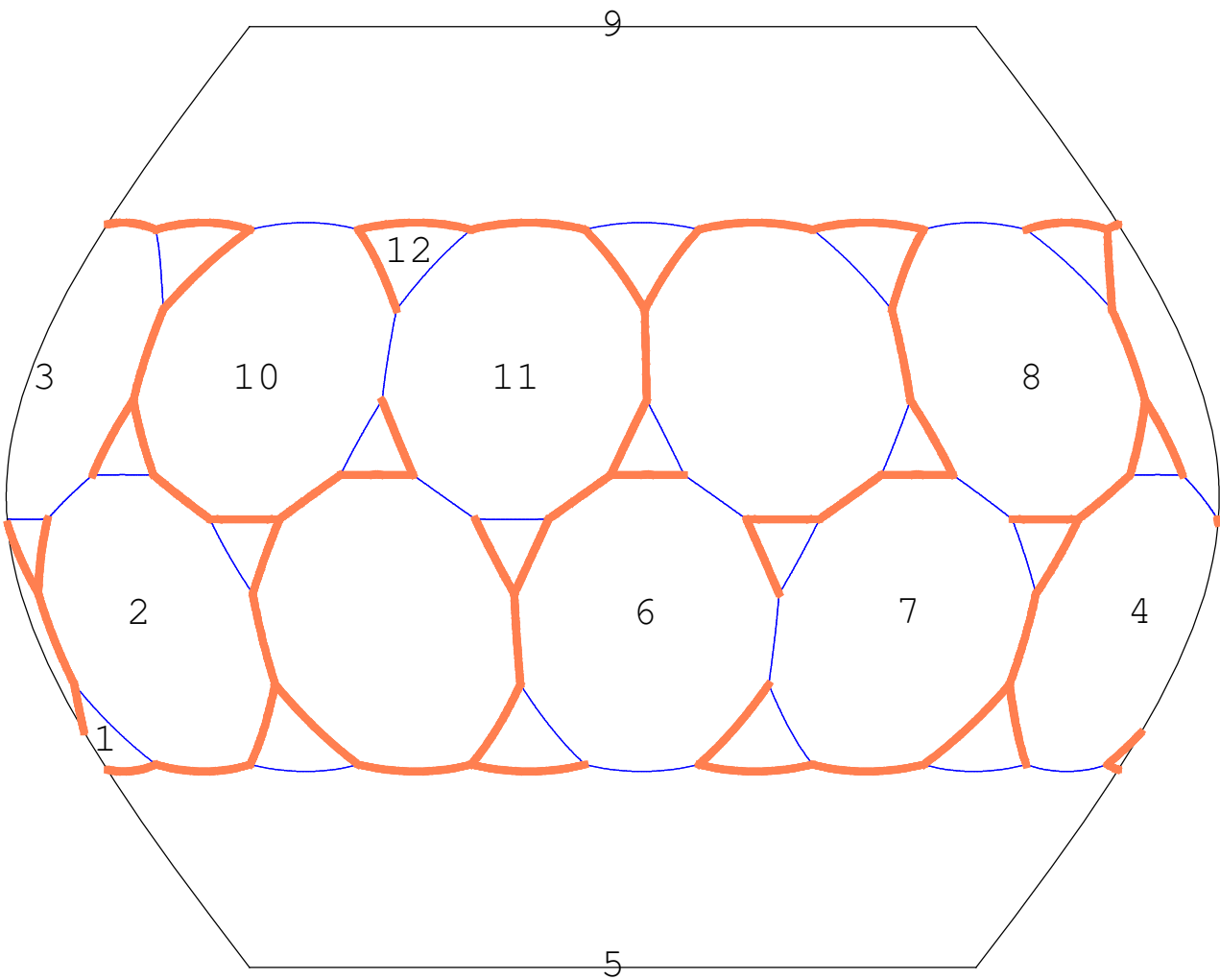
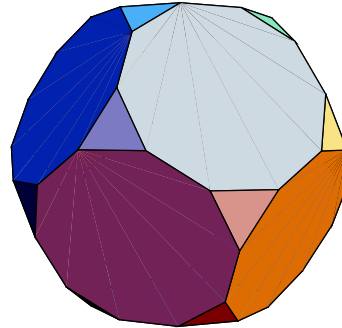
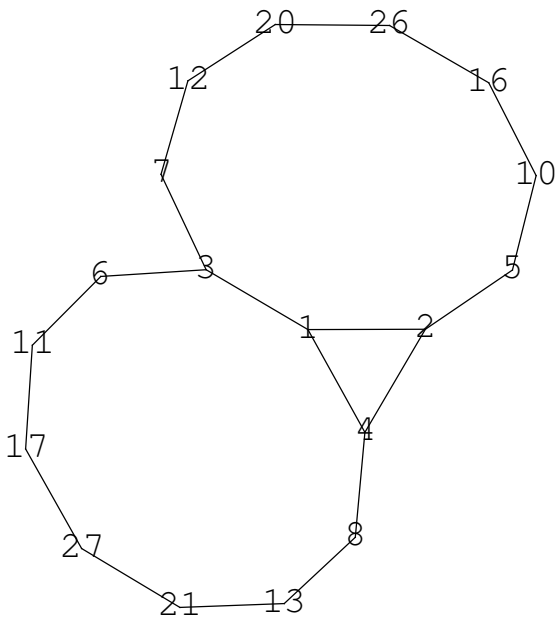

27.

rhombicosidodecahedron

{4, 3, 4, 5}

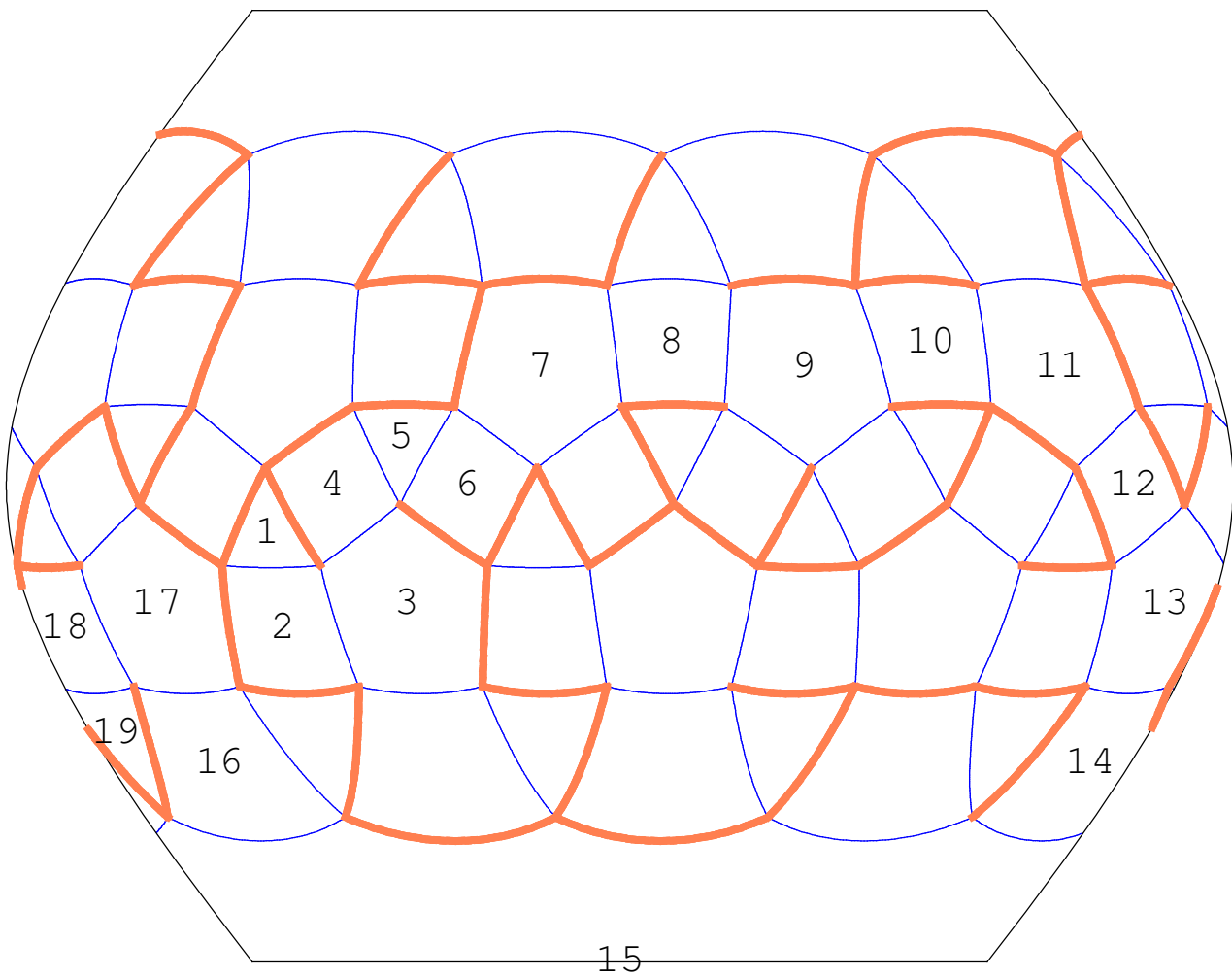
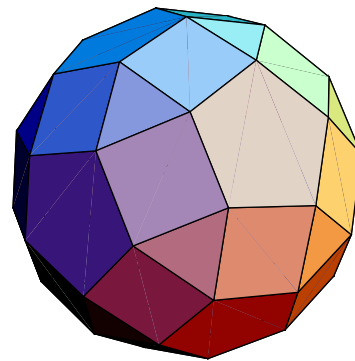
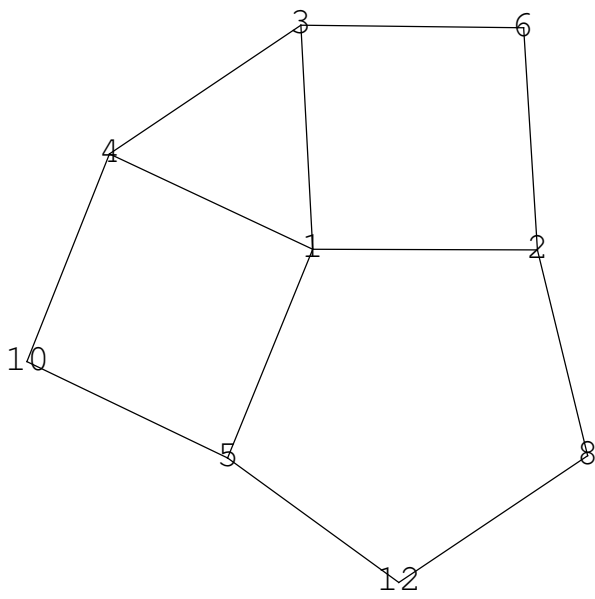

28.

truncated icosidodecahedron

{4, 6, 10}

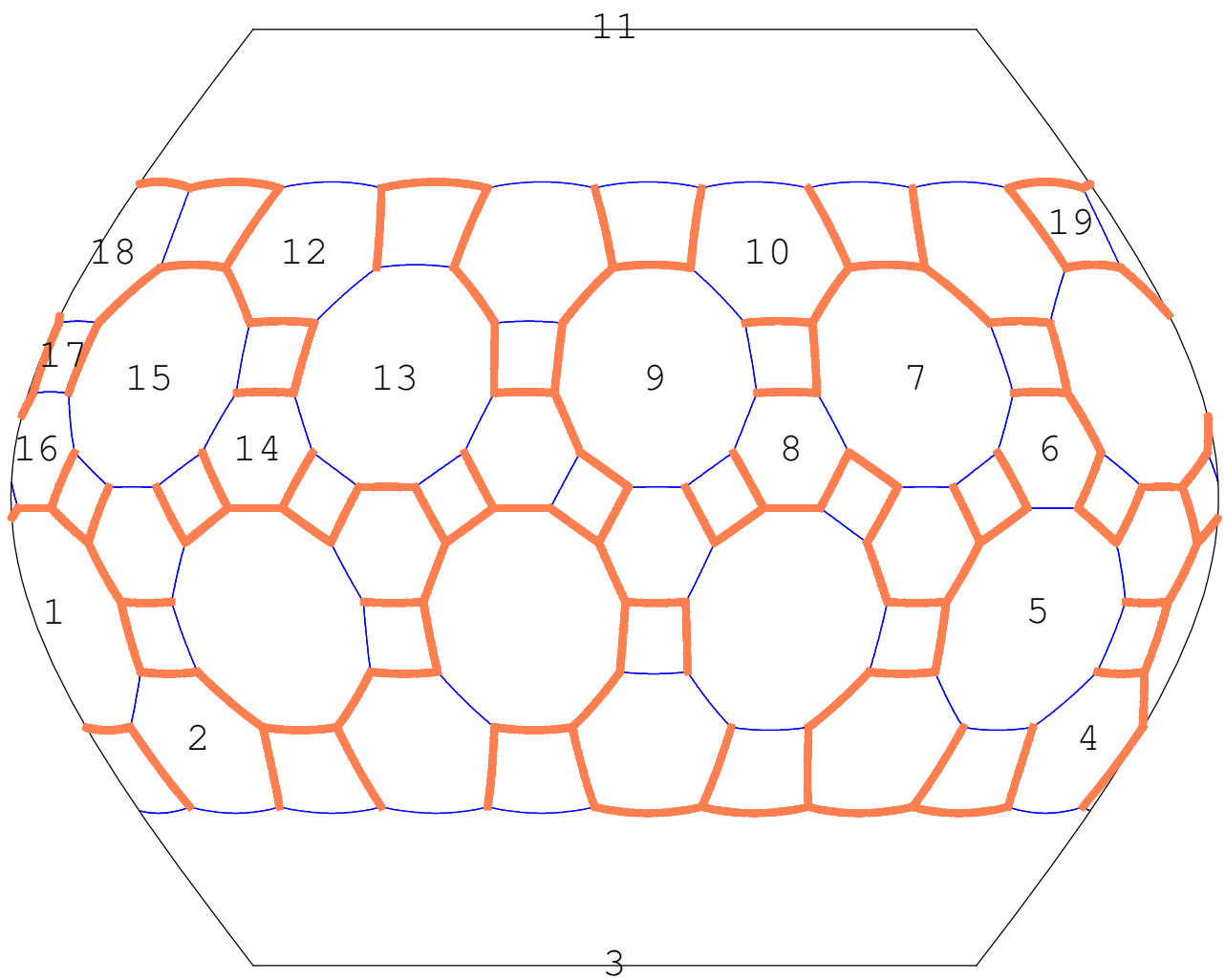
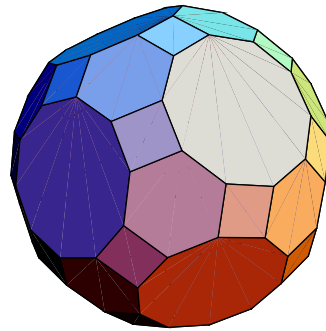
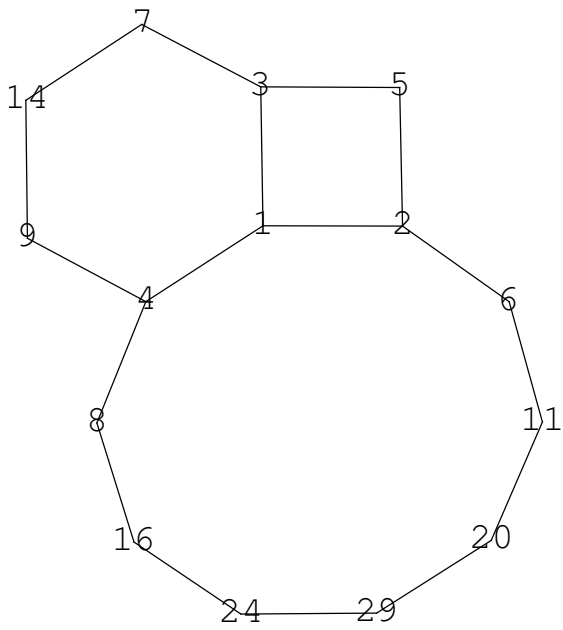

29.

snub dodecahedron

{3, 3, 3, 3, 5}

